

### A-100NF

Variable Speed

Dial Knob Control

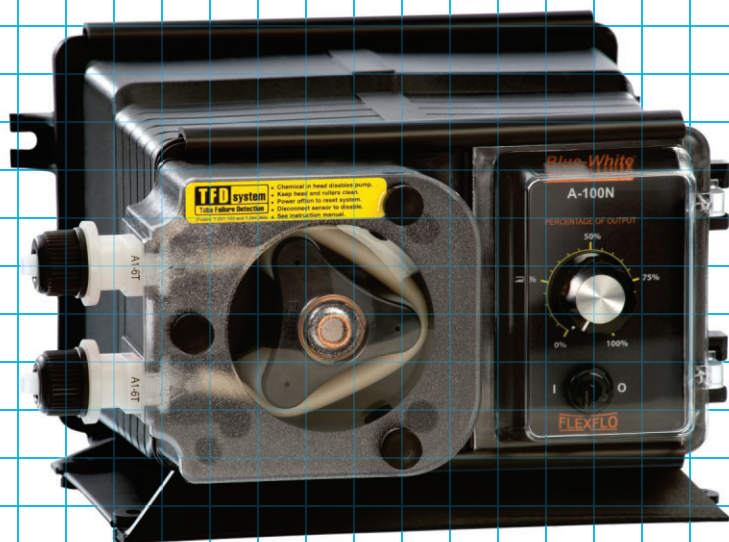

### Features:

- Peristaltic pump design does not have valves that can clog requiring maintenance.
- Self priming - even against maximum line pressure. By-pass valves are not required. Cannot vapor lock or lose prime.
- Outputs to 5.17 GPH (19.56 LPH).
- Output pressures to 100 PSI (6.9 bar).
- Output volume is not effected by changes in back pressure.
- Patented pump tube design installs easily and stays centered on the rollers without manual adjustment.
- Two pump tubes supplied with each pump. No extra tubing required.
- Easy to use dial knob speed adjustment.
- Built-in Tube Failure Detection system (TFD). Senses chemical in the pump head, shuts off the pump and activates an NPN open collector output.
- Compatible with Blue-White's output flow verification sensor system.
- Durable housing of chemical resistant Valox (PBT) thermoplastic.

### Specifications:

Max. working pressure:	.....100 psig (6.9 bar)	Voltage (amp draw):	.....115VAC/60Hz, 1ph (.513 amp max)
Max. fluid temperature:	.....130° F (54° C)		230VAC/60Hz, 1ph (.563 amp max)
Max. ambient temperature:	...14° to 110° F/ -10° to 43° C		220VAC/50Hz, 1ph (.660 amp max)
Output adjustment range:	....10-100% in 1% increments		240VAC/50Hz, 1ph (.585 amp max)
Duty cycle:	.....Continuous	Power Cord Plug Type:	.....115V60Hz = NEMA 5/15 (USA)
Maximum viscosity:	.....5,000 Centipoise		230V60Hz = NEMA 6/15 (USA)
Maximum suction lift:	.....30 ft. Water 0 psig		220V50Hz = CEE 7/VI (EUROPE)
Maximum Solids:	.....50% by volume		240V50Hz = CEE 7/VI (EUROPE)
Enclosure:	.....NEMA 3R, (IP23)	Approximate shipping wt:	...12 lb. (5.4 kg)

### Materials of Construction:

#### Wetted components:

Pump Tube Assembly:	.....Flex-A-Prene <sup>®</sup> , Flex-A-Thane <sup>®</sup> or FKM tubing
	PVDF tube assembly connection fittings
Suction Tubing:	.....Clear PVC
Suction Strainer:	.....Natural Polypropylene
Discharge Tubing:	.....Natural Polyethylene (LLDPE)
Injection/Check valve:	
Body & insert:	.....Polypropylene (optional PVDF)
Check Ball:	.....Ceramic
Spring:	.....Hastelloy C-276
Ball Seat O-ring:	.....TFE/P (optional EP)
Static Seal O-ring:	.....FKM (optional EP)

#### Non-Wetted components:

Pump Head & Enclosure:	.....Valox <sup>®</sup> (PBT) thermoplastic
Pump Head Cover:	.....Clear Acrylic
Cover Screws:	.....300 Stainless, Polypropylene cap
Roller Assembly:	
Rotor:	.....Valox <sup>®</sup> (PBT)
Rollers:	.....Nylon
Roller Bearings:	.....Bronze
Motor Shaft:	.....Nickel plated steel
TFD System Sensor pins:	.....Hastelloy C-276
Power Cord:	.....3 conductor, SJTW-A Water-resistant

#### Dimensions:

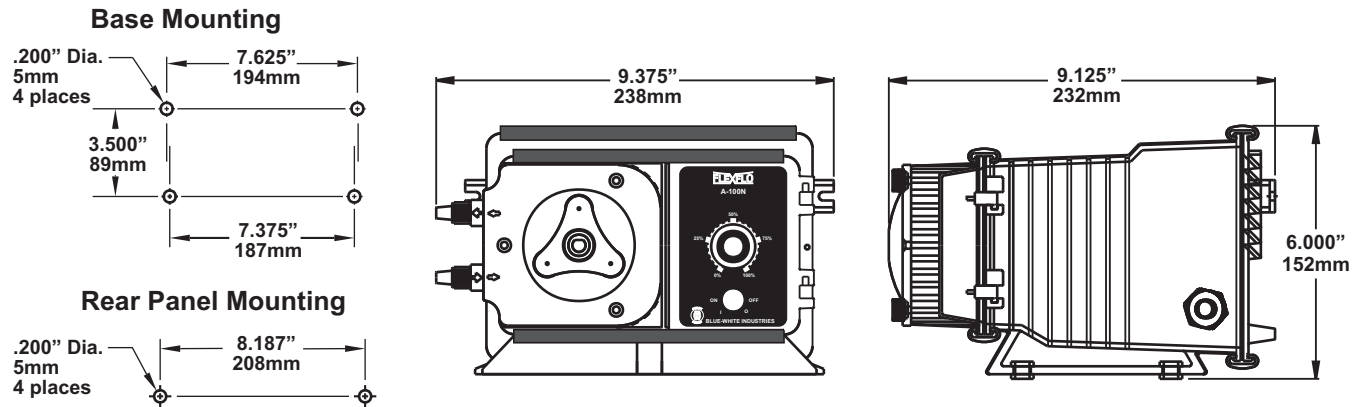

#### Model Number Matrix:

MODEL A1N [ ] [ ] F - [ ] - [ ]

##### Maximum Motor RPM

- 0 = 14 RPM
- 1 = 30 RPM
- 2 = 45 RPM
- 3 = 60 RPM

##### Power Supply

- 0 = 115V60Hz
- 1 = 220V50Hz
- 2 = 230V60Hz
- 8 = 240V50Hz AS 3112 (Australia/New Zealand)
- 9 = 230V50Hz BS 1363 (UK)

##### Output Control

- V = Digital speed control with external input
- F = Analog speed control
- E = Digital batch timer with external input
- A = Analog timer, 60 sec. Cycle - 100% duty
- C = Analog timer, 5 sec. Cycle - 100% duty
- S = Analog timer, 60 sec. Cycle - 10% duty
- X = No output control - fixed feed rate

##### Miscellaneous Options (not required)

- 1 = T140-6V injector replaces A-014N-6A
- 2 = C-340V footvalve replaces C-342-6 strainer
- 5 = A-014NK-6A injector PVDF
- 6 = Jumper set for digital square wave input
- T7 = 7 gallon chemical tank system
- T15 = 15 gallon chemical tank system
- T30 = 30 gallon chemical tank system
- X = NSF61 certified (ships without accessories)

##### Tubing Connection Type

- T = Compression tube nuts

##### Pump Tube Size and Material

- 1 = 1/4" OD Flex-A-Thane®
- 2 = 3/8" OD Flex-A-Thane®
- 3 = 7/16" OD Flex-A-Thane®
- 4 = 1/4" OD Flex-A-Prene®
- 5 = 5/16" OD FKM
- 6 = 3/8" OD Flex-A-Prene®
- 7 = 7/16" OD Flex-A-Prene®
- 8 = 7/16" OD Flex-A-Chem®

#### Maximum Flow rate and pressure capacities:

Tube no.	Tubing Material	14 RPM MODELS					30 RPM MODELS					45 RPM MODELS					60 RPM MODELS				
		ml/m	oz/m	lph	gph	PSI(bar)	ml/m	oz/m	lph	gph	PSI(bar)	ml/m	oz/m	lph	gph	PSI(bar)	ml/m	oz/m	lph	gph	PSI(bar)
1	Flex-A-Thane®	15	0.51	0.90	0.24	65(4.5)	35	1.18	2.10	0.55	65(4.5)	54	1.83	3.24	0.86	65(4.5)	67	2.26	4.02	1.06	65(4.5)
2	Flex-A-Thane®	32	1.08	1.92	0.51	65(4.5)	75	2.54	4.50	1.19	65(4.5)	115	3.89	6.90	1.82	65(4.5)	140	4.73	8.40	2.22	65(4.5)
3	Flex-A-Thane®	73	2.47	4.37	1.16	50(3.5)	173	5.85	10.38	2.74	50(3.5)	261	8.82	15.66	4.14	50(3.5)	326	11.01	19.56	5.17	50(3.5)
4	Flex-A-Prene®	6	0.20	0.36	0.10	100(6.9)	13	0.44	0.78	0.21	100(6.9)	21	0.71	1.26	0.33	100(6.9)	25	0.85	1.50	0.40	75(5.2)
5	FKM	11	0.37	0.66	0.17	25(1.7)	26	0.88	1.56	0.41	25(1.7)	39	1.31	2.34	0.62	25(1.7)	48	1.62	2.88	0.76	25(1.7)
6	Flex-A-Prene®	18	0.61	1.08	0.29	100(6.9)	42	1.42	2.52	0.67	100(6.9)	63	2.13	3.78	1.00	100(6.9)	79	2.67	4.74	1.25	75(5.2)
7	Flex-A-Prene®	57	1.92	3.42	0.90	50(3.5)	138	4.66	8.28	2.19	50(3.5)	200	6.76	12.00	3.17	50(3.5)	250	8.45	15.00	3.96	50(3.5)
8	Flex-A-Chem®	40	1.35	2.40	0.63	50(3.5)	84	2.80	5.04	1.31	50(3.5)	140	4.73	8.40	2.22	50(3.5)	180	6.10	10.80	2.85	50(3.5)

Gallons shown are U.S. Gallons

#### Replacement Pump Tubes:

Pump Model Number Suffix	Pump Tube Part Number	Pump Tube Material	Nominal Pump Tube OD
-1T	A1-1T	Flex-A-Thane®	1/4" (6,4mm)
-2T	A1-2T	Flex-A-Thane®	3/8" (9,5mm)
-3T	A1-3T	Flex-A-Thane®	7/16" (11,1mm)
-4T	A1-4T	Flex-A-Prene®	1/4" (6,4mm)
-5T	A1-5T	FKM	5/16" (7,9mm)
-6T	A1-6T	Flex-A-Prene®	3/8" (9,5mm)
-7T	A1-7T	Flex-A-Prene®	7/16" (11,1mm)
-8T	A1-8T	Flex-A-Chem®	7/16" (11,1mm)