

# FLEXFLO<sup>®</sup>

Peristaltic Metering Pump



## Series A2

<b>1.0</b>	<b>Introduction</b>	<b>4</b>
1.1	Available Models	4
<b>2.0</b>	<b>Specifications</b>	<b>5</b>
2.1	Materials of Construction	6
<b>3.0</b>	<b>Features</b>	<b>7</b>
3.1	Agency Listings	7
<b>4.0</b>	<b>Installation</b>	<b>8</b>
4.1	Mounting Location	8
4.2	Dimensions	8
4.3	Installing Injection Fitting and Strainer	9
<b>5.0</b>	<b>Power Connections</b>	<b>10</b>
5.1	A2F Wiring Terminal and I/O Schematics	11
5.2	A2V Wiring Terminal and I/O Schematics	12
<b>6.0</b>	<b>How to Operate Flex-Pro - Control Pad</b>	<b>13</b>
6.1	A2F Touch Pad Layout	13
6.2	A2V Touch Pad Layout	14
6.3	Mode Descriptions	15
<b>7.0</b>	<b>Mode0 - Set Remote Start/Stop</b>	<b>16</b>
7.1	Mode 0 - Set TFD Sensitivity	17
7.2	Mode 0 - Set FVS (flow verification system)	18
7.3	Mode 0 - Set 4-20mA Output	20
<b>8.0</b>	<b>Mode 1 - Manual Operation</b>	<b>22</b>
8.1	Mode 1 - Manual Operation Screen Shots	23
<b>9.0</b>	<b>Mode 2 - 4-20mA Input Operation (A2V PUMP ONLY)</b>	<b>24</b>
9.1	Mode 2 - 4-20mA Input Screen Shots	25
<b>10.0</b>	<b>Mode 3 - Frequency Input (Hz) Operation (A2V PUMP ONLY)</b>	<b>26</b>
<b>11.0</b>	<b>Mode 4 - Pulse Batch (low speed pulse) Operation (A2V PUMP ONLY)</b>	<b>28</b>
11.1	Mode 4 - Pulse Batch Operation Screen Shots	29
<b>12.0</b>	<b>Pump Tube Timer</b>	<b>30</b>
<b>13.0</b>	<b>TFD (Tube Failure Detection)</b>	<b>30</b>
<b>14.0</b>	<b>Alarm Relay</b>	<b>31</b>
<b>15.0</b>	<b>Reverse Rotation</b>	<b>31</b>
<b>16.0</b>	<b>Tube Replacement</b>	<b>32</b>
16.1	Tube Removal	32
16.2	Tube Installation	33
<b>17.0</b>	<b>Pump Maintenance</b>	<b>34</b>
<b>18.0</b>	<b>Output Versus Fluid Viscosity</b>	<b>35</b>
<b>19.0</b>	<b>A2 Replacement Parts List</b>	<b>36</b>
19.1	Tube Matrix	37
<b>20.0</b>	<b>Warranty</b>	<b>38</b>
<b>21.0</b>	<b>Model Number Matrix</b>	<b>39</b>

**READ THE INSTRUCTION MANUAL PRIOR TO INSTALLATION AND USE.**



+1 (714) 893 - 8529



[sales@blue-white.com](mailto:sales@blue-white.com)



[customerservice@blue-white.com](mailto:customerservice@blue-white.com)



5300 Business Drive  
Huntington Beach, CA 92649

## 1.0 Introduction

Congratulations on purchasing Flex-Pro variable speed Peristaltic Metering Pump. A peristaltic pump is a type of positive displacement pump used for pumping a variety of fluids.

Your Flex-Pro pump is pre-configured for tubing that shipped with your metering pump. Tubing assembly has an Identification number printed on tube for easy re-order; such as ND, NH, etc.

**Please Note:** Your new pump has been pressure tested at factory with clean water before shipping. You may notice trace amounts of clean water in pre-installed tube assembly. This is part of our stringent quality assurance program at Blue-White Industries.

## 1.1 Available Models

Tube Material / Size	Feed Rate			Max Pressure	Max Temperature
	GPH	LPH	mL/Min	PSI (bar)	°F (°C)
<b>Flex-A-Thane® Tube</b>					
GE	Up to 4.0	Up to 15.2	Up to 253	65 (4.50)	130 (54)
GG	Up to 9.3	Up to 35.2	Up to 587	65 (4.50)	130 (54)
G2G	Up to 14.98	Up to 56.7	Up to 945	65 (4.50)	130 (54)
<b>Flex-A-Prene® Tube</b>					
ND	Up to 1.7	Up to 6.5	Up to 108	125 (8.60)	185 (85)
NEE	Up to 4.44	Up to 16.8	Up to 280	110 (7.60)	185 (85)
NGG	Up to 17.2	Up to 65.1	Up to 1085	110 (7.60)	185 (85)
<b>Flex-A-Chem® Tube</b>					
TH	Up to 14.3	Up to 54	Up to 900	50 (3.45)	130 (54)

### Optional Extended Brackets

Stainless Steel extended brackets allow pump to be securely mounted to most any surface; floor, shelf, or skid. Brackets lift pump up 4-1/2 inches (11.43 cm), for easy pump access in hard to reach areas.

- Raise metering pump 4-1/2 inches (11.43 cm) off ground or a surface.
- Made out of tough Stainless Steel.
- Provides a stable mounting surface.

Model #	Description
72000-380	Extended Mounting Bracket, 1 Pair, SS, 4 SS Screws



## 2.0 Specifications

<b>Maximum Working Pressure</b>	125 psig (8.6 bar)
<b>Maximum Fluid Temperature</b>	185 °F (85 °C)
<b>Maximum Ambient Temperature</b>	14 °F to 115 °F/ -10 °C to 46 °C
<b>Maximum Viscosity</b>	12,000 Centipoise
<b>Maximum Suction Lift</b>	30 ft. Water at sea level (14.7 atm psi)
<b>Operating Voltage</b>	115VAC/60Hz, 1ph (1.5 Amp Maximum)
	230VAC/60Hz, 1ph (0.7 Amp Maximum)
	220VAC/50Hz, 1ph (1.0 Amp Maximum)
	240VAC/50Hz, 1ph (1.0 Amp Maximum)
	230VAC/50Hz, 1ph (1.0 Amp Maximum)
<b>Power Cord Options</b>	115V60Hz = NEMA 5/15 (USA)
	230V60Hz = NEMA 6/15 (USA)
	220V50Hz = CEE 7/VII (EU)
	240V50Hz = AS 3112 (Australia/New Zealand)
	230V50Hz = BS 1363/A (UK)
<b>Motor</b>	Brushed DC, 1/8 H.P.
<b>Duty cycle</b>	Continuous
<b>Motor Speed Adjustment Range</b>	100:1, (1.0% – 100% motor speed) Max. rpm = 130
<b>Display</b>	Backlit LCD, UV resistant
<b>Keypad</b>	Eight button positive action tactile switch keypad
<b>Maximum Overall Dimensions</b>	7-1/2" W x 10-1/4" H x 14" D (19 W x 26 H x 35.6 D cm)
<b>Product Weight</b>	28.4lb. (12.9 Kg)
<b>Approximate Shipping Weight</b>	35 lb. (15.9 Kg)
<b>Enclosure</b>	NEMA 4X (IP66)
<b>RoHS Compliant</b>	Yes
<b>Standards</b>	cETLus, CE

## 2.1 Materials of Construction

---

### Non-wetted Components:

**Enclosure:** 413 Aluminum (Polyester powder coated)

**Pump Head:** Valox® (PBT) thermoplastic

**Pump Head Cover:** Polycarbonate

Permanently lubricated sealed motor shaft support ball bearing.

**Cover Screws:** Stainless steel

### Roller Assembly:

Rotor: Valox® (PBT)

Rollers: Nylon

Roller Bearings: SS Ball Bearings

**Motor Shaft:** Chrome plated steel

**TFD System Sensor:** Hastelloy C-276

**Power Cord:** 3 conductor, SJTW-A water-resistant

**Tube Installation Tool:** GF Nylon

**Mounting Brackets and Hardware:** 316 Stainless steel

---



---

### Wetted Components:

#### Pump Tube Assembly:

Tubing : Flex-A-Prene®, Flex-A-Chem® or Flex-A-Thane®

Adapter Fittings : PVDF

#### Injection/Back-Flow Check Valve:

Body & Insert: PVDF

Check Ball: Ceramic

Spring: Hastelloy C-276

Ball Seat O-Ring: TFE/P

Static Seal O-Ring: FKM

#### Ancillary Items Provided:

##### With “S” Tubing Type Only:

Suction Tubing: 3/8” OD x 1/4” ID x 10’ Clear PVC

Discharge Tubing: 3/8” OD x 1/4” ID x 10’ Polyethylene

Suction Strainer: Polypropylene

##### With “B” Tubing and “M” M/NPT Connections Only:

#### Suction Strainer:

Body: PVDF

Check Ball: Ceramic

Ball Seat O-Ring: TFE/P

##### With “C” Tri-clamp and “Q” Quick Disconnect Connections\* Only:

(Available for ND, NEE, NGG, and G2G only)

---

**NOTE:** \* Quick Disconnect Valves sold separately.

### 3.0 Features

Peristaltic pump design does not have valves that can clog requiring maintenance.

Self priming - even against maximum line pressure. By-pass valves are not required. Cannot vapor lock or lose prime.

Variable speed DC motor.

Rated for continuous duty (24X7).

Specially engineered tubing for long life at high pressures. Meets FDA 21 CFR requirements for food contact applications.

Patented Tube Failure Detection (TFD) system. Senses tube failure by detecting chemical in pump head.

Backlit LCD displays motor speed, input signal values, service and alarm status.

Precision molded squeeze alignment rollers for optimum squeeze, unparalleled accuracy, and tube life.

Heavy duty rotor - single piece plastic rotor means no flexing and increased accuracy with no metal springs or hinges to corrode.

Inject at maximum pressure in either direction (clockwise and counter clockwise).

Compatible with Blue-White's output Flow Verification Sensor (FVS) system.

### 3.1 Agency Listings



This pump is ETL listed to conform to the following:  
UL Standard 778 as a motor operated water pump  
CSA Standard C22.2 as process control equipment



This pump complies to the Machinery Directive 98/37/EC, BS EN 60204-1, Low Voltage Directive 73/23/EC BS EN 61010-1, EMC Directive 89/336/EC, BS EN 50081-1/BS EN 50082-1.



Symbol	Explanation
	WARNING, risk of electric shock
	CAUTION, refer to users' guide
	GROUND, PROTECTIVE CONDUCTOR TERMINAL

#### Enclosure Rating:

**NEMA 4X:** Constructed for either indoor or outdoor use to provide a degree of protection to personnel against incidental contact with enclosed equipment; to provide a degree of protection against falling dirt, rain, sleet, snow, windblown dust, splashing water, and hose-directed water; and that will be undamaged by external formation of ice on enclosure.

**IP66:** No ingress of dust; complete protection against contact. Water projected in powerful jets against enclosure from any direction shall have no harmful effects.

### 4.0 Installation

<b>CAUTION</b> 	Risk of chemical overdose. Be certain pump does not overdose chemical during backwash and periods of no flow in circulation system.
<b>CAUTION</b> 	Always wear protective clothing, face shield, safety glasses and gloves when working on or near your metering pump. Additional precautions should be taken depending on solution being pumped. Refer to MSDS precautions from your solution supplier.
<b>CAUTION</b> 	All diagrams are strictly for guideline purposes only. Always consult an expert before installing metering pump on specialized systems. Metering pump should be serviced by qualified persons only.

### 4.1 Mounting Location

Choose an area located near chemical supply tank, chemical injection point, and electrical supply. Install pump where it can be easily serviced.

316SS Mounting brackets are included. Mount pump to a secure surface using enclosed mounting hardware.

Mount pump close to injection point. Keep inlet (suction) and outlet (discharge) tubing as short as possible. Longer discharge tubing increases back pressure at pump head.

**Important!** Install a back flow prevention check valve at discharge side of pump to prevent system fluid from flowing back through pump during tube replacement or if tube should rupture. **Important!**

A pressure relief valve is recommended at discharge of pump to prevent premature wear and damage to pump tube in event discharge line becomes blocked.

Flex-Pro does not require back pressure. Keep discharge pressure as low as possible to maximize tube life.

### 4.2 Dimensions

A2 Dimensions		
Dim	Inches	cm
A	10-1/4"	26
B	7-1/2"	19
C	14"	35.6
D	9-1/2"	24.1
E	11"	27.9
F	3-3/8"	8.6
G	1-1/4"	3.2
H	2-1/2"	6.4
I	4-7/8"	12.3
J	7-1/4"	18.5
K	7-3/4"	19.7

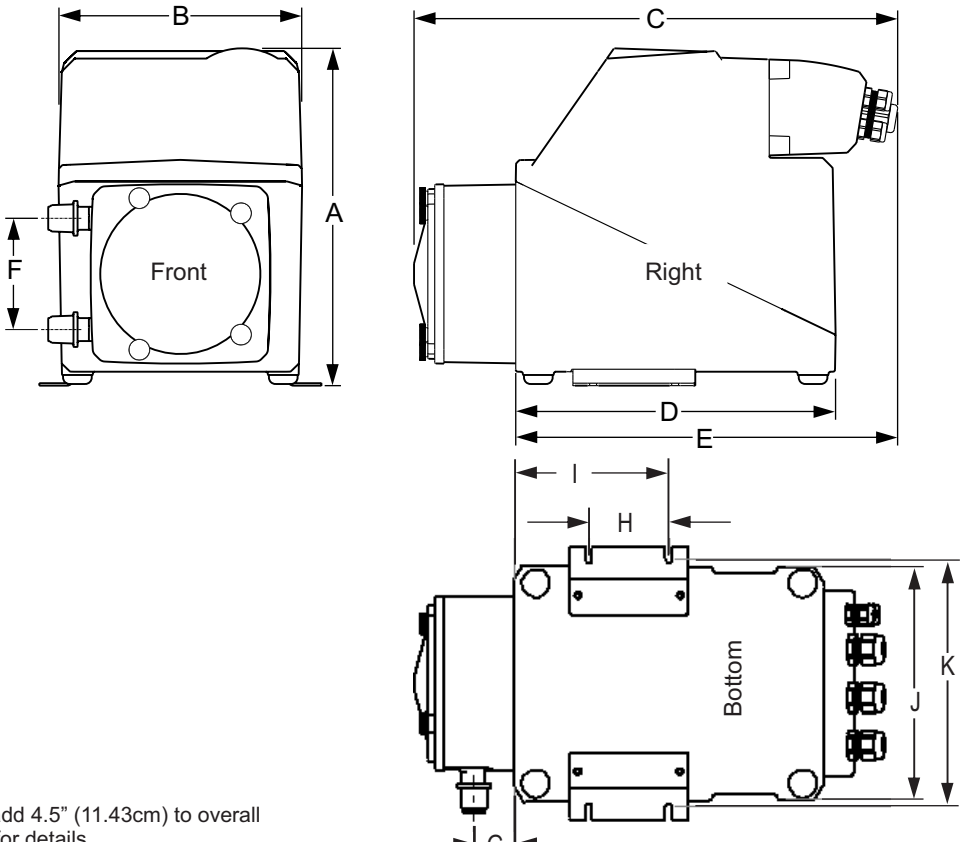

The technical drawings show three views of the metering pump: a front view, a right-side view, and a bottom view. Dimension lines A through K are used to specify various measurements. The front view shows dimensions B (width), A (height), and F (port height). The right-side view shows dimensions C (total length), D (inlet length), E (total length to outlet), and I (inlet diameter). The bottom view shows dimensions G (width), H (inlet diameter), J (total length), and K (height to base).

*Note:* Optional Extended Bracket add 4.5" (11.43cm) to overall height (dimension A). See page 3 for details





### 4.3 Installing Injection Fitting and Strainer

**CAUTION** Proper eye and skin protection must be worn when installing and servicing pump.

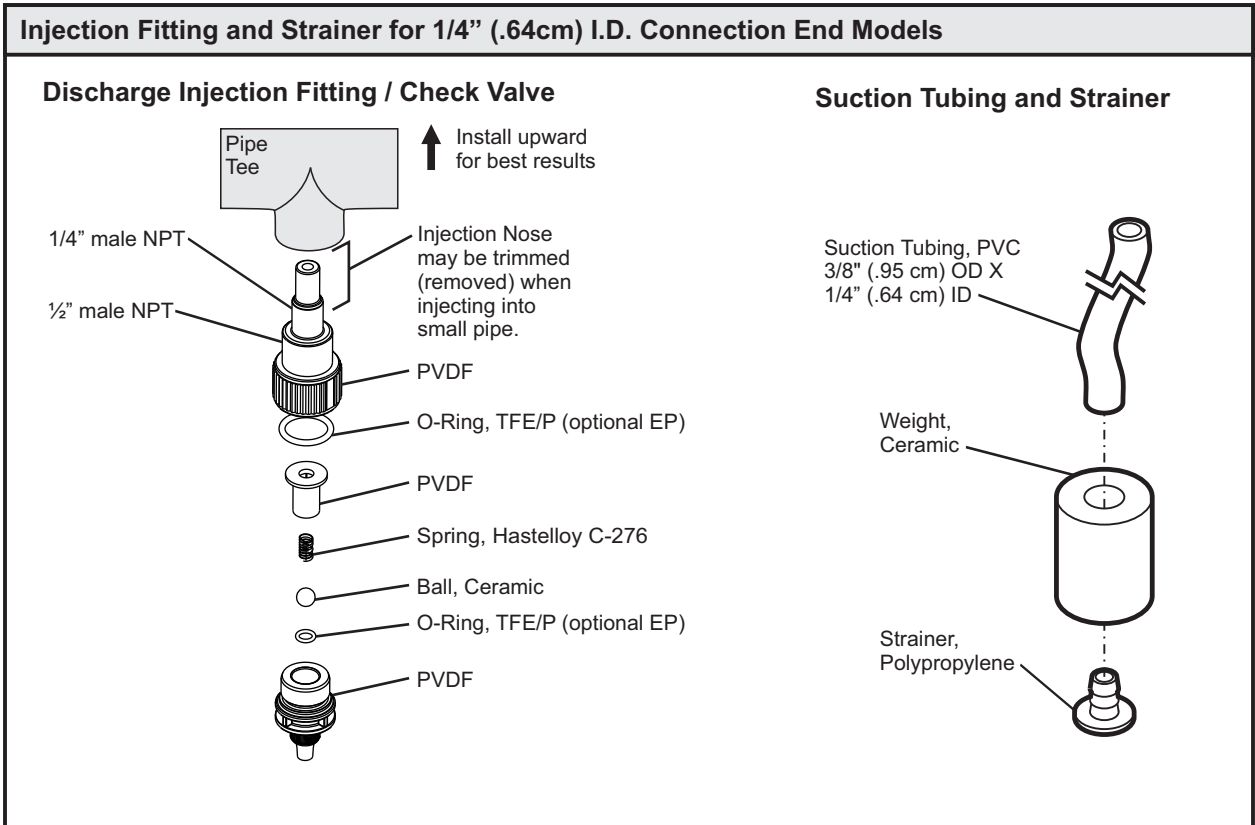
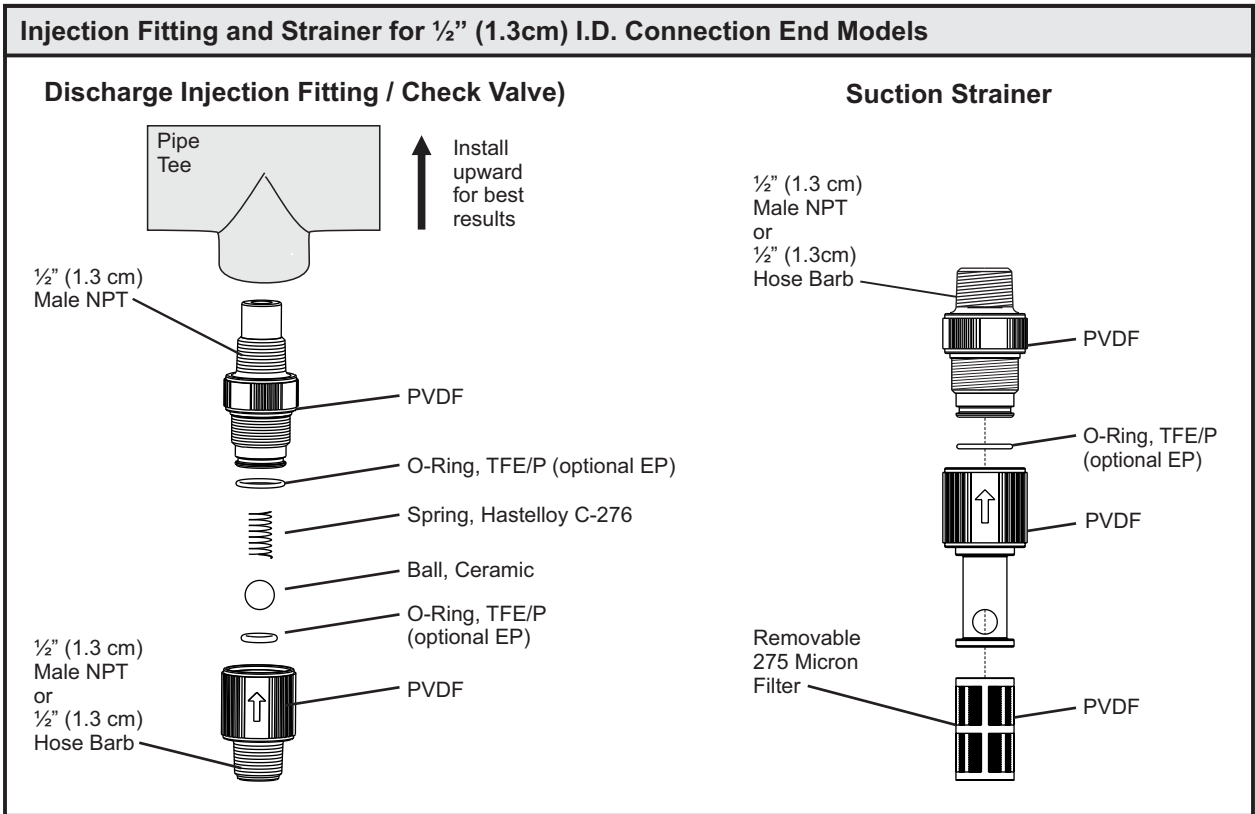
**CAUTION** This Pump Has Been Evaluated for Use with Water Only.



## 5.0 Power Connections

<b>WARNING</b> 	Risk of electric shock – cord connected models are supplied with a grounding conductor and grounding-type attachment plug. To reduce risk of electric shock, be certain that it is connected only to a properly grounded, grounding-type receptacle.
<b>WARNING</b> 	Electrical connections and grounding (earthing) must conform to local wiring codes. Be certain that a grounding conductor is connected to terminal T11-1 located in wiring compartment.
<b>WARNING</b> 	Risk of electric shock - Disconnect electricity before removing wiring compartment cover.

Be certain to connect pump to proper supply voltage. Using incorrect voltage will damage pump and may result in injury. Voltage requirement is printed on pump serial label.

Input power: 115VAC 50/60 Hz 1.5 amp or 230/240VAC 50/60 Hz 0.7 amp.

Power switch located in Junction Box.

Use voltage your power cord is rated for.

Cord connected models are supplied with a ground wire conductor and a grounding type attachment plug (power cord). To reduce risk of electric shock, be certain that power cord is connected only to a properly grounded, grounding type receptacle.

Permanently connected models must be properly grounded. Be certain that a grounding conductor is connected to terminal T11-1 located in wiring compartment.

Never strap control (input / output) cables and power cables together.

**Power Interruption:** This pump has an auto-restart feature which will restore pump to operating state it was in when power was lost.

**Note:** *When in doubt regarding your electrical installation, contact a licensed electrician.*

### WIRING COMPARTMENT COVER

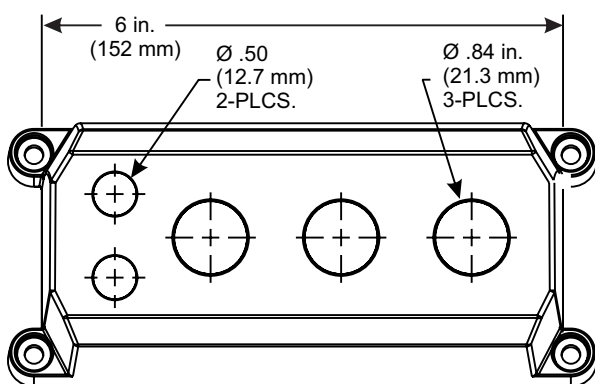

### POWER CORD OPTIONS

Three power cord plug types available. Power cord length is 6 feet (3.83 meters)



115V 60Hz  
NEMA 5/15 (USA)  
max: 125V AC

230V 60Hz  
NEMA 6/15 (USA)  
max: 250V AC

240V 50Hz  
CEE 7/VII (EU)  
max: 250V AC

### Included cable and conduit connectors:

QTY.	DESCRIPTION
Qty: 2	.50 Inch (12.7 Mm) Liq-tight Hole Plugs (mat'l = Neoprene), Pre-installed
Qty: 3	.875 Inch (22.2 Mm) Liq-tight Hole Plugs (mat'l = Neoprene), 2 Pre-installed
Qty: 2	.50 Inch (12.7 Mm) Liq-tight Connectors For Pass Thru Cords (mat'l = Nylon) Acceptable Cable Diameter .12 To .26 Inch (3.0 To 6.5 Mm), Not Installed
Qty: 3	.875 Inch (22.2 Mm) Liq-tight Connectors For Pass Thru Cords (mat'l = Nylon) Acceptable Cable Diameter .20 To .40 Inch (5.1 To =10.0 Mm), 1 Pre-installed W/ Power Cord Models
Qty: 2	Metallic Liq-tight Connectors For .50 Inch Flexible Conduit (mat'l = Die Cast Zinc), Not Installed

### 5.1 A2F Wiring Terminals and I/O Schematics

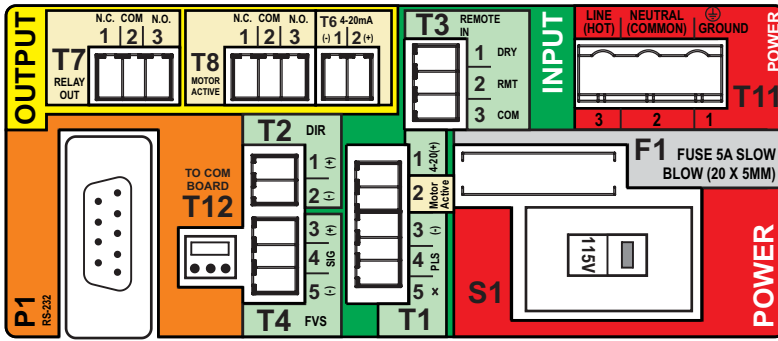

Terminal Block	Replacement #
2 Positions	90010-304
3 Positions	90010-305
5 Positions	90010-306



Terminals T1 Thru T8  
Plug type  
16 - 24 AWG

Power Input Terminal T11  
Plug type  
14 - 30 AWG

**WARNING** Risk of electric shock - All wiring must be insulated and rated 300V minimum.

FUNCTION	TERM	PIN #	RATING	ELECTRICAL SP.	BLOCK DIAGRAM
<b>INPUT:</b> FVS SYSTEM (FLOW VERIFICATION SENSOR) FV SENSOR ONLY	T4	3	(+) POSITIVE		
	T4	4	SIGNAL		
	T4	5	(-) NEGATIVE		
<b>INPUT:</b> FVS SYSTEM (FLOW VERIFICATION SENSOR) FS or FP MICRO-FLO FLOW METER ONLY	T4	4	SIGNAL		
	T4	5	(-) NEGATIVE		
<b>INPUT:</b> REMOTE START / STOP (DRY CONTACT C.)	T3	1	(+) POSITIVE	NO VOLTAGE	<p><b>NOTE:</b> USE ONLY DRY CONTACT FOR REMOTE S/S WHEN USING 4-20mA INPUT</p>
	T3	2	(-) NEGATIVE		
<b>INPUT:</b> REMOTE START / STOP (WET CONTACT C.)	T3	2	(+) POSITIVE	6 TO 30 VOLT DC 1 AMP MAX.	
	T3	3	(-) NEGATIVE		
<b>OUTPUT:</b> RELAY, 3 AMP	T7	1	NORM. CLOSED	Form C 3 AMP MAX AT 250 VAC, 3 AMP MAX AT 30 VOLT DC	
	T7	2	COMMON		
	T7	3	NORM. OPEN		
<b>INPUT:</b> POWER	T11	1	GROUND	115V OR 230V AC MANUAL SWITCH 50 / 60 HZ 100W	
	T11	2	NEUTRAL		
	T11	3	LINE (HOT)		
<b>FUSE</b>	F1	N/A	5 AMP	5A SLOW BLOW (20 X 5MM)	

### 5.2 A2V Wiring Terminals and I/O Schematics

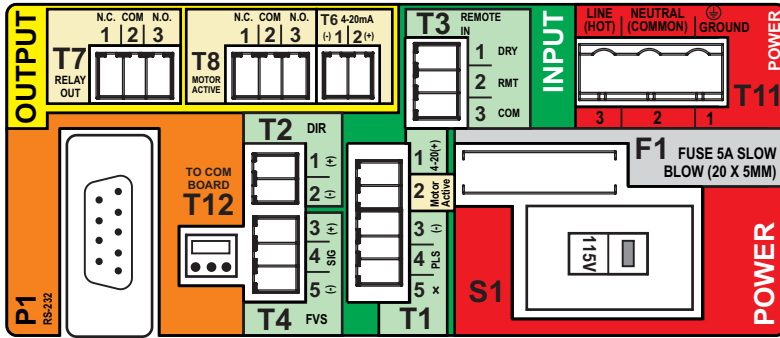

Terminal Block	Replacement #
2 Positions	90010-304
3 Positions	90010-305
5 Positions	90010-306

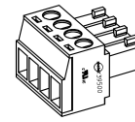

Terminals T1 Thru T8  
Plug type  
16 - 24 AWG

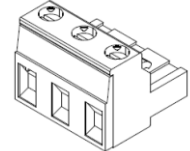

Power Input Terminal T11  
Plug type  
14 - 30 AWG

**WARNING** Risk of electric shock - All wiring must be insulated and rated 300V minimum.

Shielded cables should be used on all input signal wires.

FUNCTION	TERM	PIN #	RATING	ELECTRICAL SP.	BLOCK DIAGRAM
INPUT: 4-20 mA	T1	1	(+) POSITIVE	120 OHM IMPEDANCE, NON POWERED LOOP	
	T1	3	(-) NEGATIVE		
INPUT: FREQUENCY, AC SINE WAVE, TTL, CMOS	T1	3	(-) NEGATIVE	0-1000 HZ MAX.	
	T1	4	(+) POSITIVE		
INPUT: FVS SYSTEM (FLOW VERIFICATION SENSOR) FV SENSOR ONLY	T4	3	(+) POSITIVE		
	T4	4	SIGNAL		
	T4	5	(-) NEGATIVE		
INPUT: FVS SYSTEM (FLOW VERIFICATION SENSOR) FS or FP MICRO-FLO FLOW METER ONLY	T4	4	SIGNAL		
	T4	5	(-) NEGATIVE		
INPUT: REMOTE START / STOP (DRY CONTACT C.)	T3	1	(+) POSITIVE	NO VOLTAGE	
	T3	2	(-) NEGATIVE		
INPUT: REMOTE START / STOP (WET CONTACT C.)	T3	2	(+) POSITIVE	6 TO 30 VOLT DC 1 AMP MAX.	
	T3	3	(-) NEGATIVE		
OUTPUT: 4-20 mA	T6*	2	(+) POSITIVE	120 OHM RESISTANCE ACTIVE LOOP	
	T6*	1	(-) NEGATIVE		
OUTPUT: RELAY, 3 AMP	T7	1	NORM. CLOSED	Form C 3 AMP MAX AT 250 VAC, 3 AMP MAX AT 30 VOLT DC	
	T7	2	COMMON		
	T7	3	NORM. OPEN		
OUTPUT: OPEN COLLECTOR MOTOR ACTIVE	T1	2	SIGNAL	5 TO 24 VDC	
	T1	3	COMMON		
OUTPUT: MOTOR ACTIVE (CONTACT CLOSURE)	T8*	1	NORM. CLOSED	Form C 1 AMP MAX AT 125 VAC, 0.8 AMP MAX AT 30 VOLT DC	
	T8*	2	COMMON		
	T8*	3	NORM. OPEN		
INPUT: POWER	T11	1	GROUND	115V OR 230V AC MANUAL SWITCH 50 / 60 HZ 100W	
	T11	2	NEUTRAL		
	T11	3	LINE (HOT)		
FUSE	F1	N/A	5 AMP	5A SLOW BLOW (20 X 5MM)	

Note: T6 & T8 terminals only available in Models with option 3 "4-20mA output signal"

## 6.0 How to Operate the Flex-Pro - Control Pad

### 6.1 A2F Touch Pad Layout

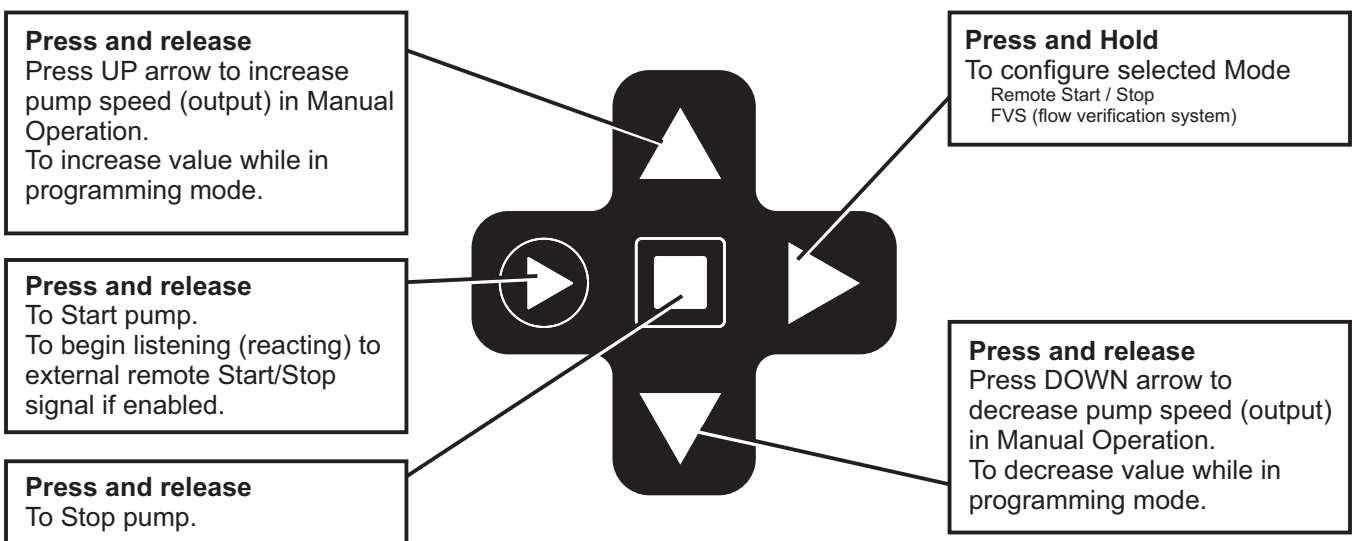
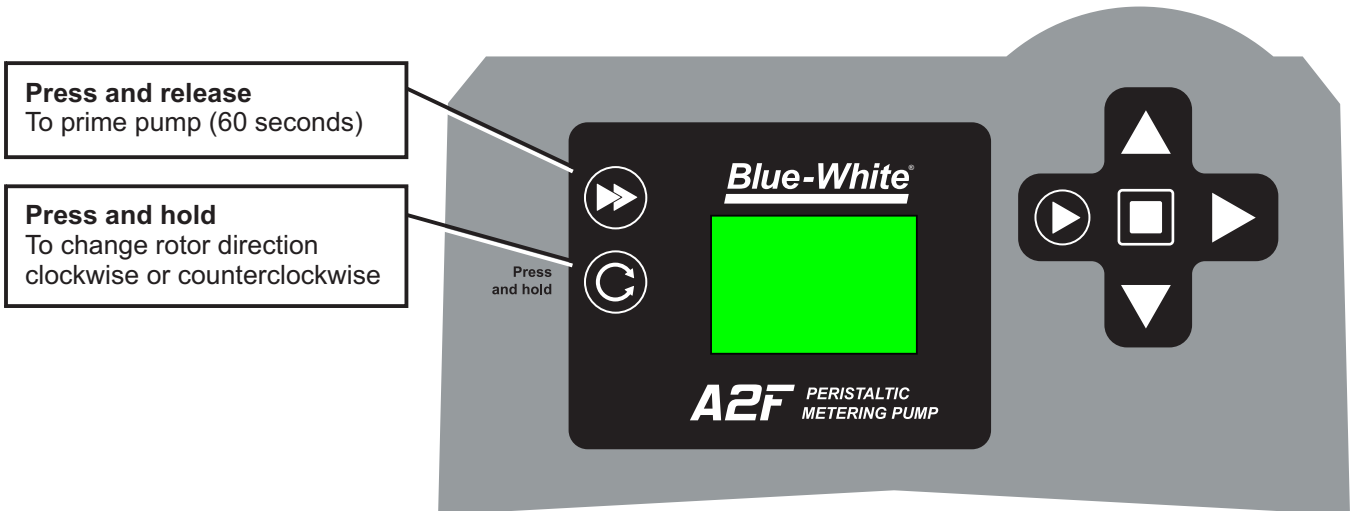

Tube Life Timer	
<p>To view amount of run time hours on currently installed tube.</p> <p>START + DOWN arrow displays current pump tube timer.</p> <p>Hold down START button, then press and release DOWN arrow.</p>	

## 6.2 A2V Touch Pad Layout

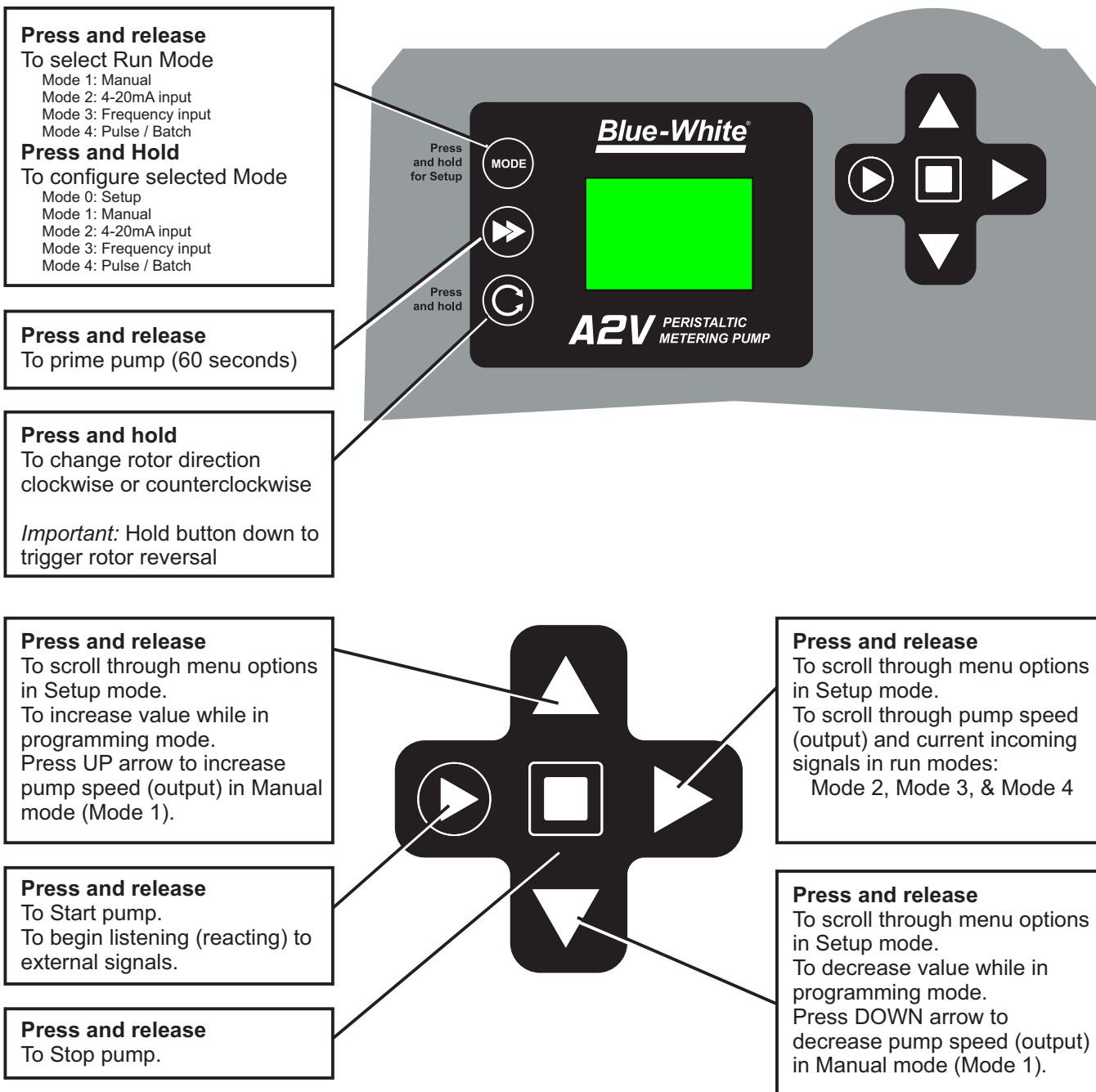

### Tube Life Timer

To view amount of run time hours on currently installed tube.

START + DOWN arrow displays current pump tube timer.

Hold down START button, then press and release DOWN arrow.



### 6.3 Mode Descriptions

Press and Hold to configure:

- Remote Start / Stop
- TFD (Tube Failure Detection) sensitivity
- FVS (Flow Verification Sensor) time delay - requires sensor
- 4-20 mA output, available on certain models



Mode 0

**Mode 1 - Manual**

Run pump locally by selecting pump speed (1 - 100%).

- Control speed by using up or down arrows after start button is pressed.
- Control speed by entering Mode 1 setup and selecting desired pump speed (1 - 100%)

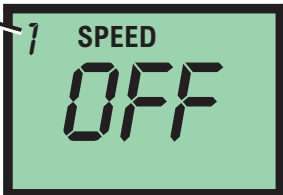

Mode 1

**Mode 2 - 4-20 mA Input Signal**

Run pump remotely via external 4-20 mA signal.

- Press and Hold "Select Run Mode" button with Mode 2 selected to configure settings.
- Select Mode 2 and press START button to allow pump to be controlled by external 4-20mA signal.

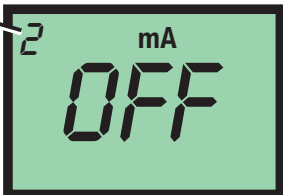

Mode 2

**Mode 3 - Frequency (Hz) Input Signal**

Run pump remotely via external high frequency (Hz) signal.

- Press and Hold "Select Run Mode" button with Mode 3 selected to configure settings.
- Select Mode 3 and press START button to allow pump to be controlled by external frequency (Hz) signal.



Mode 3

**Mode 4 - Pulse Batch Input Signal (low speed pulse)**

Run pump remotely via external low speed pulse signal.

- Press and Hold "Select Run Mode" button with Mode 4 selected to configure settings.
- Select Mode 4 and press START button to allow pump to be controlled by external low speed pulse signal.



Mode 4

## 7.0 Mode 0 - Set Remote Start / Stop

Used to remotely start and stop pump using a dry contact closure signal.  
When activated; CLOSE = START and OPEN = STOP.

Set to NO = Remote Start / Stop is disabled  
Set to Yes = Remote Start / Stop is enabled

Can be used with external foot pedal, PLC, contact closure or other similar external devices.

Default setting = No (disabled)

### Step 1

Press and release STOP button

Note: Mode cannot be changed while pump is in running.

Press and release SELECT RUN MODE button multiple times until Mode 0 is selected.

Mode 0



### Step 2

With Mode 0 selected, press and hold SELECT RUN MODE button until 'Remote' icon begins flashing.

Default setting 'NO' will also be visible when entering remote start / stop setup.

Note: If 'YES' had been selected previously, then 'YES' will be displayed on screen.

Mode 0

Remote Icon



### Step 3

Press and release DOWN arrow to change setting to 'YES.'

To change setting back to 'NO' press and release UP arrow.

Mode 0



### Step 4

After you've made your selection, press and release RIGHT arrow button. This saves your setting.

You can now modify other settings in Mode 0 or you can exit Setup by pressing and holding SELECT RUN MODE button for a few seconds until you return to Run screen.

Mode 0



Running pump with Remote Start / Stop enabled, 'REMOTE' icon will always be visible on lower left side of screen. Pump will display 'STBY' (standby) if pump is in stop mode via contact closure signal. **Please use caution in this mode, pump can start at anytime. If you must perform maintenance to pump, press and release STOP button.**



## 7.1 Mode 0 - Set TFD Sensitivity

Flex-Pro pump is equipped with a Tube Failure Detection (TFD) system which is designed to stop pump in event pump tube should rupture and chemical enters pump head. This patented system is capable of detection presence of a large number of chemicals including Sodium Hypochlorite (chlorine), Hydrochloric (muriatic) Acid, Sodium Hydroxide, and many others.

Minimum and Maximum setting = 75 % to 100%

Default Setting = 75% (75% is recommended; triggers with most water treatment chemicals without false alarms)

Important: 100% sensitivity setting may trigger false alarm by washdown or rain. 100% setting is only recommended when absolutely necessary.

### Step 1

Press and release STOP button

Note: Mode cannot be changed while pump is in running.

Press and release SELECT RUN MODE button multiple times until Mode 0 is selected.

Mode 0



### Step 2

With Mode 0 selected, press and hold SELECT RUN MODE button until 'Remote' icon begins flashing.

This indicates that you've entered Setup menu.

Mode 0

Remote  
Icon



### Step 3

Press and release RIGHT arrow button to scroll through menu until you see TFD icon.

If you pass TFD screen, continue to press and release RIGHT arrow button until TFD icon appears.

Mode 0



### Step 4

TFD icon will appear for 1 second, followed by numbers.

Numbers indicate sensitivity value of TFD.

Press and release UP arrow button to increase sensitivity value.

Press and release DOWN arrow button to decrease sensitivity value.

Mode 0



### Step 5

After you've made your selection, press and release RIGHT arrow button. This saves your setting.

You can now modify other settings in Mode 0 or you can exit Setup by; press and hold SELECT RUN MODE button for a few seconds until you return to Run screen.

Mode 0



**Confirm chemical detection** - To determine if your chemical will be detected by system, remove pump tube and rotor. Place a small amount of chemical in bottom of pump head - just enough to cover sensors. Turn on pump. If TFD system detects chemical, pump will stop after two seconds and TFD alarm screen will display. Press STOP button to clear alarm.

## 7.2 Mode 0 - Set FVS (flow verification system)

Flow verification sensor sold separately.

Flow verification system is designed to stop pump in an event sensor does not detect flow during pump operation. Indicating an empty chemical tank, clogged injection fitting, loose tubing connection, etc.

To allow pump to clear any gasses that may have accumulated over time, an alarm delay time value from 1 to 255 seconds must be programmed.

Note: An alarm delay of 000 seconds disables FVS system.

### Step 1

Press and release STOP button

Note: Mode cannot be changed while pump is in running.

Press and release SELECT RUN MODE button multiple times until Mode 0 is selected.

Mode 0



### Step 2

With Mode 0 selected, press and hold SELECT RUN MODE button until 'Remote' icon begins flashing. This indicates that you've entered Setup menu.

Mode 0

Remote  
Icon

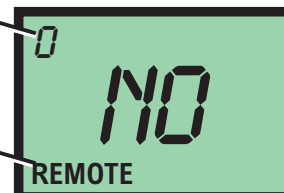

### Step 3

Press and release RIGHT arrow to scroll through menu until you see FVS icon. If you pass FVS screen, continue to press and release RIGHT arrow button until FVS icon appears.

Mode 0



### Step 4

FVS icon will appear for 1 second, followed by numbers. These numbers indicate delay time setting for FVS. Select a delay time in seconds. Delay time is amount of time pump will wait to receive a pulse from sensor until an alarm it triggered. A delay time of 00 deactivates FVS feature.

Mode 0



### Step 5

After you've made your selection, press and release RIGHT arrow button. This saves your setting. You can now modify other settings in Mode 0 or you can exit Setup by; press and hold SELECT RUN MODE button for a few seconds until you return to Run screen.

Mode 0



**Time-out** - Flex-Pro pumps have a time-out setting of 20 seconds while in configuration menus. If built-in timer exceeds 20 seconds without a button being pressed, then pump will exit configuration menu. Changes will only be saved after RIGHT arrow button is pressed and released.

## 7.2 Mode 0 - Set FVS (flow verification system) - Continued

Flow Verification Sensor is designed to give you two installation options.

Sensor can be installed:

- Directly on pumphead of A2 pump, suction side.
- Anywhere on suction side of A2 pump.

Wiring for sensor can be connected directly to an A2 pump. Pump will stop pumping if sensor detects no flow. A relay will then close allowing for remote alarm indication or initiation of a back-up injector pump. **Install FVS Flow Sensor** - Flow Verification Sensor should be installed on inlet (suction) side of pump tube. Sensor includes a PVC tubing insert, located inside sensors female thread connection, that is designed to seal sensor onto pump tube inlet adapter. Thread sensor onto pump tube until tubing insert is snug against pump tube inlet fitting - do not over-tighten.

Sensor Model Number	Published Flow Range	Actual Working Range with Flex-Pro Pump
	ML/Min	ML/Min
FV-100	30-300	30-200
FV-200	100-1000	50-900
FV-300	200-2000	100-1800
FV-400	300-3000	300-3000
FV-500	500-5000	500-5000
FV-600	700-7000	700-7000



**Confirm FVS flow range** - Flow Verification Sensor (FVS) will only function within its operating range. See chart for available ranges.

Example: Sensor model FV-100 has an operation range of 30-300 ml/min when used as a flowmeter. However, due to pressure drop across sensor, pump's suction capability is limited to 14.7 psi. When used as a Flow Verification Sensor with a peristaltic pump, effective operating range is reduced to 30-200 ml/min.

NOTE: If pump output is less than 30 ml/min, sensor will not detect chemical and a signal will not be sent to pump, resulting in an alarm condition.

NOTE: For low viscosity (water-like) fluids only. Consult factory if attempting to use with viscous fluids.

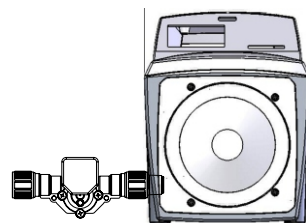

## 7.3 Mode 0 - Set 4-20mA Output

Available on certain models.

Sends a configurable 4-20 mA signal, based on pump rotor speed, to an external device. This feature can be used to control other pumps (in sync / proportionally), data logging systems, and other external devices for plant automation.

Default setting: Minimum Speed = 4 mA signal output  
Maximum Speed = 20 mA signal output

Set to NO = disabled  
Set to Yes = enabled

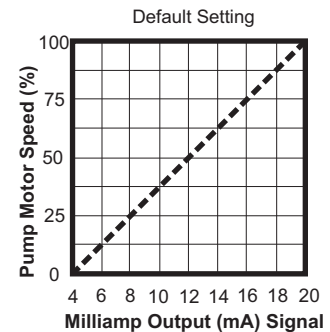

### Step 1

Press and release STOP button

Note: Mode cannot be changed while pump is in running.

Press and release SELECT RUN MODE button multiple times until Mode 0 is selected.

Mode 0



### Step 2

With Mode 0 selected, press and hold SELECT RUN MODE button until 'Remote' icon begins flashing. This indicates that you've entered Setup menu.

Mode 0

Remote Icon



### Step 3

Press and release RIGHT arrow to scroll through menu until you see 4-20 mA icon.

To select Yes, press and release DOWN arrow.

To select No, press and release UP arrow.

To begin configuring values, select Yes.

Then press and release RIGHT arrow.

Mode 0

4-20 mA Icon



### Step 4

**Minimum pump speed** will be displayed.

To increase value, press and release UP arrow.

To decrease value, press and release DOWN arrow.

To save value, press and release RIGHT arrow.

Mode 0

4-20 mA Icon

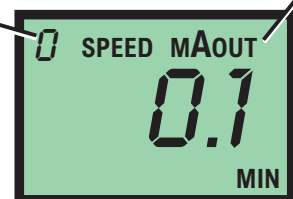

**Time-out** - Flex-Pro pumps have a time-out setting of 20 seconds while in configuration menus. If built-in timer exceeds 20 seconds without a button being pressed, then pump will exit configuration menu. Changes will only be saved after RIGHT arrow button is pressed and released.

7.3 Mode 0 - Set 4-20mA Output - Continued

**Step 5**

**Output signal at minimum speed** will now be displayed.  
 To increase value, press and release UP arrow.  
 To decrease value, press and release DOWN arrow.  
 To save value, press and release RIGHT arrow.

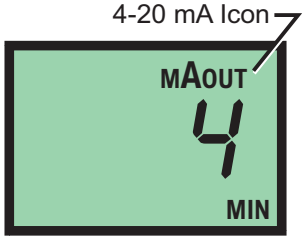

**Step 6**

**Maximum pump speed** will be displayed.  
 To increase value, press and release UP arrow.  
 To decrease value, press and release DOWN arrow.  
 To save value, press and release RIGHT arrow.

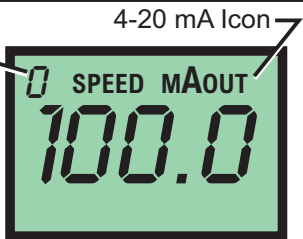

**Step 7**

**Output signal at maximum speed** will now be displayed.  
 To increase value, press and release UP arrow.  
 To decrease value, press and release DOWN arrow.  
 To save value, press and release RIGHT arrow.

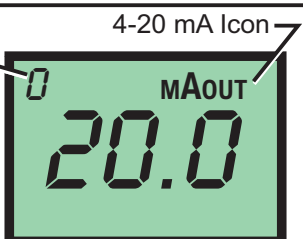

**Step 8**

You can now modify other settings in Mode 0 or you can exit Setup by; press and hold SELECT RUN MODE button for a few seconds until you return to Run screen.

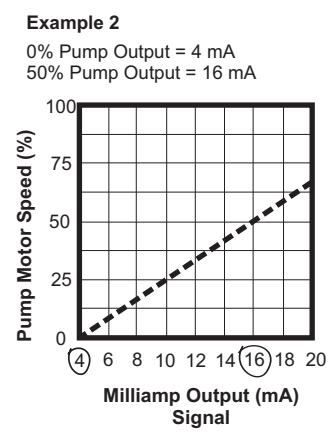
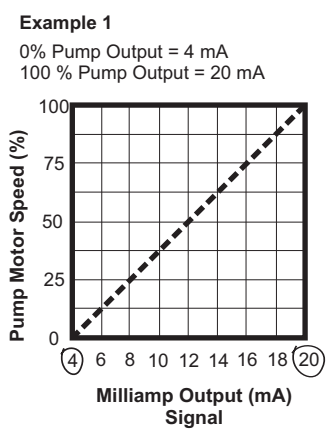
## 8.0 Mode 1 - Manual Operation

Used to manually control speed of pump.

Use UP and DOWN arrows to adjust speed while pump is running.

To select exact run speed, follow steps below.

### Step 1

Press and release STOP button

Note: Mode cannot be changed while pump is in running.

Press and release SELECT RUN MODE button multiple times until Mode 1 is selected.

Mode 1

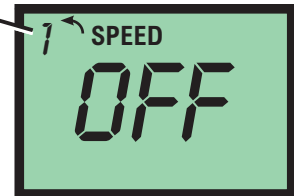

### Step 2

With Mode 1 selected, press and hold SELECT RUN MODE button until 'Speed' icon begins flashing.

This indicates that you've entered Setup menu.

Mode 1

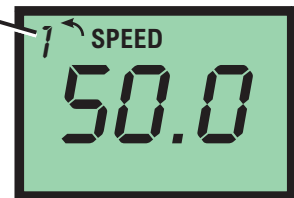

### Step 3

**Current pump speed** will be displayed.

To increase value, press and release UP arrow.

To decrease value, press and release DOWN arrow.

To save value, press and hold SELECT RUN MODE button until 'Speed' icon stop flashing.

Mode 1

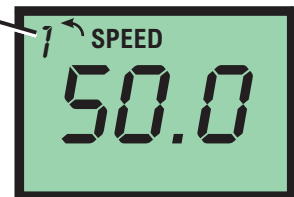

### Step 4

Pump will now operate at your pre-configured speed.

Press and release START button to start pump.

Press and release STOP button at anytime to stop pump.

Mode 1

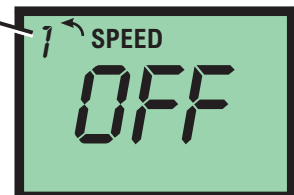

With pump operating in manual mode (Mode 1), pump speed can be changed at anytime by using UP or DOWN arrows during operation.

## 8.1 Mode 1 - Manual Operation Screen Shots

### Runtime Screen Shot 1

Display motor speed percentage.  
Pump Running in Manual Operation

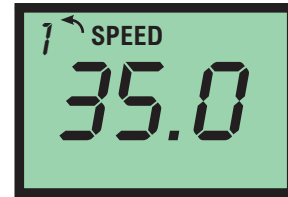

### Runtime Screen Shot 2

Display 4-20mA output (select models only)  
Press and release RIGHT arrow to view mA output value  
in real-time.

*Please note:* 4-20mA output is only available on select models. If included in  
your model; 4-20mA output must be enabled in Mode 0 (see page 16).

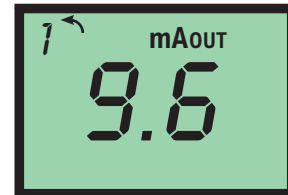

### Runtime Screen Shot 3

Display motor speed percentage.  
Press and release RIGHT arrow to view percentage of  
motor speed.

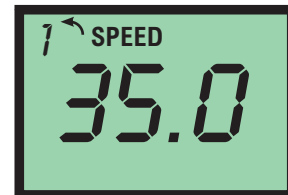

### Runtime Screen Shot 4

Display tube life timer.  
Press and hold START button.  
Press and release DOWN arrow.

Displays amount of total runtime hours on currently installed tube.  
Time will be displayed in hours.  
Timer will be display for approximately 5 seconds before returning to  
previous runtime screen.

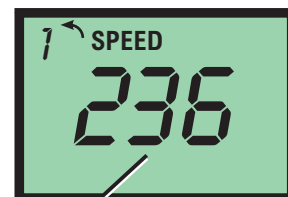
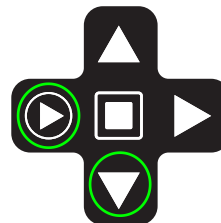

Hours

### 9.0 Mode 2 - 4-20mA Input Operation (A2V Pump Only)

Used to remotely control pump with an incoming 4-20 mA signal.

Default setting: 4 mA signal = 0.1% motor speed  
 20 mA signal = 100.0% motor speed

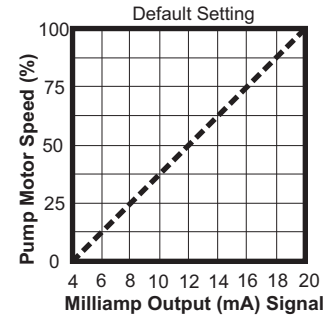

**Step 1**

Press and release STOP button  
 Note: Mode cannot be changed while pump is in running.  
 Press and release SELECT RUN MODE button multiple times until Mode 2 is selected.

**Step 2**

With Mode 2 selected, press and hold SELECT RUN MODE button until 'Speed' icon begins flashing.  
 This indicates that you've entered Setup menu.

**Step 3**

**Minimum pump speed** will be displayed.  
 To increase value, press and release UP arrow.  
 To decrease value, press and release DOWN arrow.  
 To save value, press and release RIGHT arrow.

**Step 4**

**mA value linked to minimum pump speed** will be displayed.  
 To increase value, press and release UP arrow.  
 To decrease value, press and release DOWN arrow.  
 To save value, press and release RIGHT arrow.

**Step 5**

**Maximum pump speed** will be displayed.  
 To increase value, press and release UP arrow.  
 To decrease value, press and release DOWN arrow.  
 To save value, press and release RIGHT arrow.

**Time-out** - Flex-Pro pumps have a time-out setting of 20 seconds while in configuration menus. If built-in timer exceeds 20 seconds without a button being pressed, then pump will exit configuration menu. Changes will only be saved after RIGHT arrow button is pressed and released.



9.0 Mode 2 - 4-20mA Input Operation (A2V Pump Only) - Continued

**Step 6**

**mA value linked to maximum pump speed will now be displayed.**

To increase value, press and release UP arrow.  
 To decrease value, press and release DOWN arrow.  
 To save value, press and release RIGHT arrow.

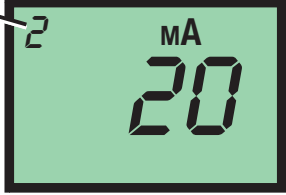

Mode 2

**Step 7**

To exit Setup, press and hold SELECT RUN MODE button for a few seconds until you return to Run screen.

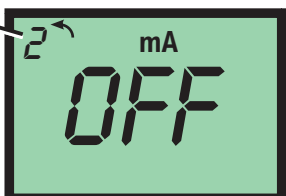

Mode 2

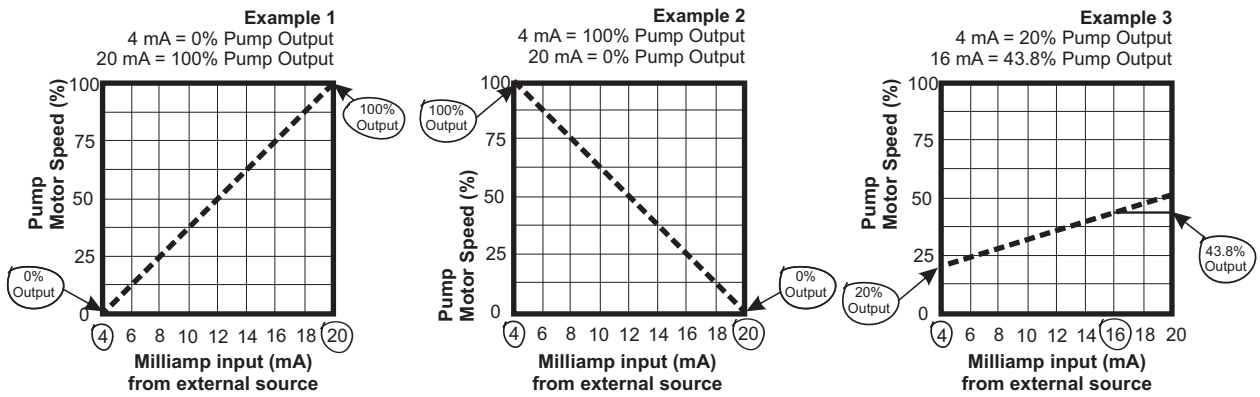

9.1 Mode 2 - 4-20mA Input Screen Shots

**Runtime Screen Shot 1**

Display **motor speed percentage**.  
 Pump Running in 4-20mA Input Operation

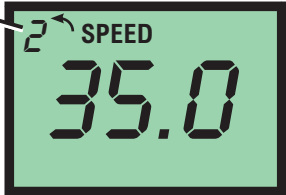

Mode 2

**Runtime Screen Shot 2**

Display current 4-20mA input signal  
 Press and release RIGHT arrow to view **mA input** value in real-time.



Mode 2

**Runtime Screen Shot 3**

Press and release RIGHT arrow again to view **mA output** value in real-time (available on select models only).  
 Press and release RIGHT arrow again to view **motor speed percentage**, as in Screen Shot 1.

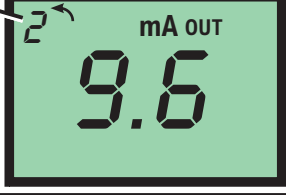

Mode 2

### 10.0 Mode 3 - Frequency Input (Hz) Operation (A2V Pump Only)

Used to remotely control pump with an incoming high speed frequency signal. Typically used with flow meters or other external devices.

Default setting: 0 Frequency (Hz) = 0% motor speed  
 1000 Frequency (Hz) = 100% motor speed

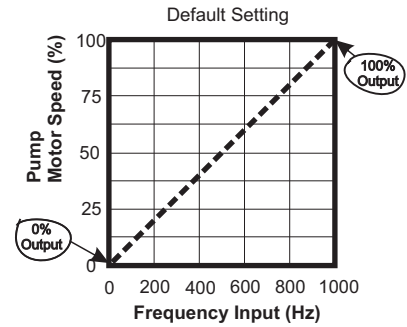

**Step 1**

Press and release STOP button  
 Note: Mode cannot be changed while pump is in running.  
 Press and release SELECT RUN MODE button multiple times until Mode 3 is selected.

Mode 3

**Step 2**

With Mode 3 selected, press and hold SELECT RUN MODE button until 'Speed' icon begins flashing.  
 This indicates that you've entered Setup menu.

Mode 3

**Step 3**

**Pump speed at minimum Frequency** will be displayed.  
 To increase value, press and release UP arrow.  
 To decrease value, press and release DOWN arrow.  
 To save value, press and release RIGHT arrow.

Mode 3

**Step 4**

**Minimum Frequency (Hz) value** will be displayed.  
 To increase value, press and release UP arrow.  
 To decrease value, press and release DOWN arrow.  
 To save value, press and release RIGHT arrow.

Mode 3

**Time-out** - Flex-Pro pumps have a time-out setting of 20 seconds while in configuration menus. If built-in timer exceeds 20 seconds without a button being pressed, then pump will exit configuration menu. Changes will only be saved after RIGHT arrow button is pressed and released.

10.0 Mode 3 - Frequency Input (Hz) Operation (A2V Pump Only) - Continued

**Step 5**

Pump speed at maximum Frequency will be displayed.  
 To increase value, press and release UP arrow.  
 To decrease value, press and release DOWN arrow.  
 To save value, press and release RIGHT arrow.



Mode 3

**Step 6**

Maximum Frequency value will now be displayed.  
 To increase value, press and release UP arrow.  
 To decrease value, press and release DOWN arrow.  
 To save value, press and release RIGHT arrow.

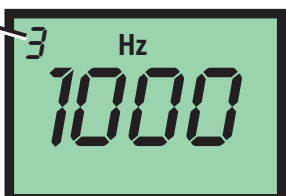

Mode 3

**Step 7**

To exit Setup, press and hold SELECT RUN MODE button for a few seconds until you return to Run screen.



Mode 3

Examples:

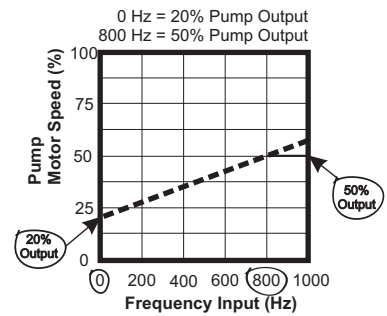
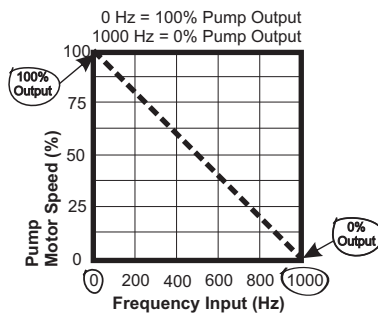
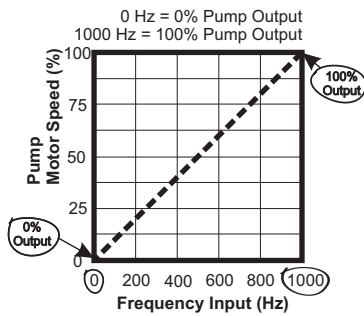

Example #1, Ultrasonic flow meter

Example #2, Paddlewheel flow meter

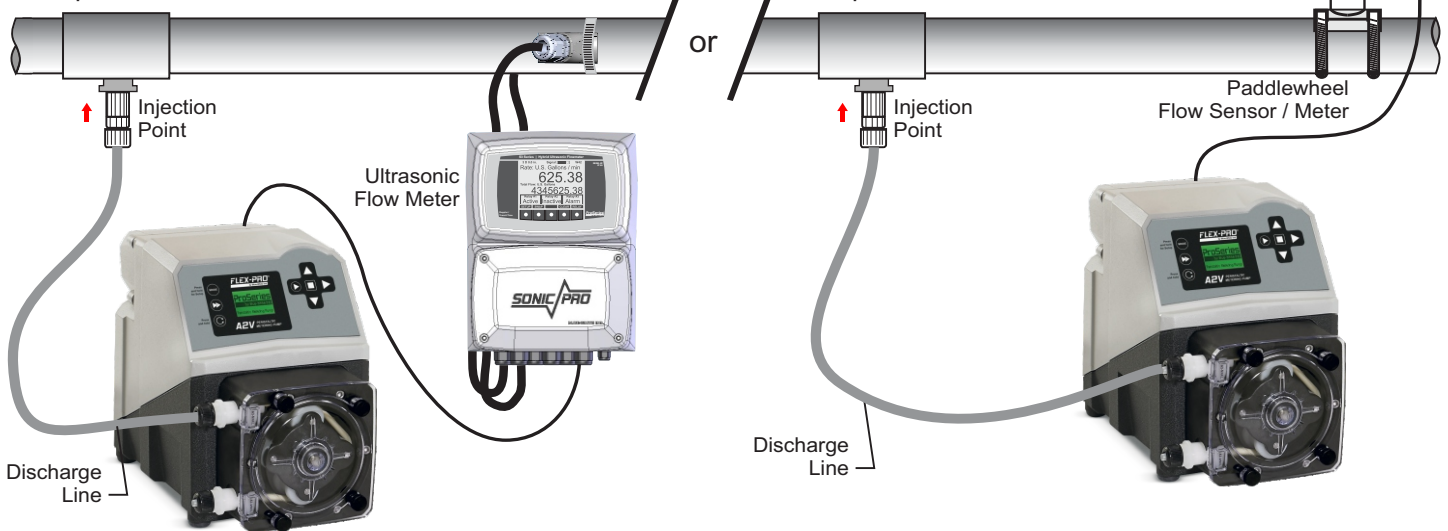

### 11.0 Mode 4 - Pulse Batch (low speed pulse) Operation (A2V Pump Only)

Used to remotely control pump with an incoming pulse signal. Can be used with an external foot pedal, a water meter, a PLC, contact closure, or other low speed pulse devices.

Default setting: 1 Pulse = 100% motor speed for 2.5 seconds

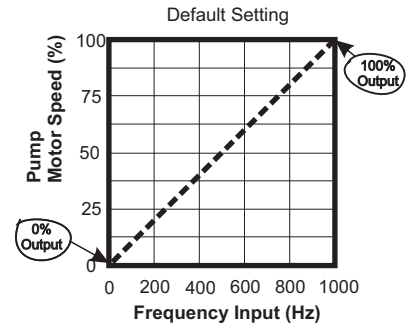

**Step 1**

Press and release STOP button  
 Note: Mode cannot be changed while pump is in running.  
 Press and release SELECT RUN MODE button multiple times until Mode 2 is selected.

Mode 4

**Step 2**

With Mode 2 selected, press and hold SELECT RUN MODE button until 'On' icon begins flashing.  
 This indicates that you've entered Setup menu.

Mode 4

**Step 3**

**Pump on-time** will be displayed in either MIN (minutes) or SEC (seconds).  
 To increase value, press and release UP arrow.  
 To decrease value, press and release DOWN arrow.  
 To save value, press and release RIGHT arrow.

Mode 4

**Step 4**

**MIN (minutes) or SEC (seconds)** will be displayed in lower right hand corner. This value will be linked to Pump on-time number in previous screen.  
 To change this setting, press and release either UP arrow or DOWN arrow.  
 To save value, press and release RIGHT arrow.

Mode 4

MIN or SEC

**Time-out** - Flex-Pro pumps have a time-out setting of 20 seconds while in configuration menus. If built-in timer exceeds 20 seconds without a button being pressed, then pump will exit configuration menu. Changes will only be saved after RIGHT arrow button is pressed and released.

**11.0 Mode 4 - Pulse Batch (low speed pulse) Operation (A2V Pump Only) - Continued**

**Step 5**  
**Number of pulses to trigger pump start** will be displayed.  
 To increase value, press and release UP arrow.  
 To decrease value, press and release DOWN arrow.  
 To save value, press and release RIGHT arrow.

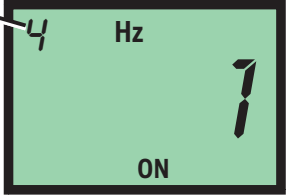

The LCD screen displays '4' in the top left corner, 'Hz' in the top right, the number '7' in the center, and 'ON' at the bottom. A line points from the text 'Mode 4' to the '4' in the top left corner.

**Step 6**  
**Pump speed during on-time** will now be displayed.  
 Pump will run at this speed after selected number of pulses is reached from previous menu.  
 To increase value, press and release UP arrow.  
 To decrease value, press and release DOWN arrow.  
 To save value, press and release RIGHT arrow.

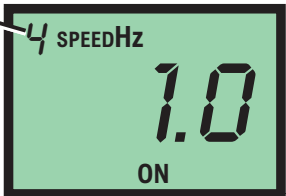

The LCD screen displays '4' in the top left corner, 'SPEED Hz' in the top right, the number '1.0' in the center, and 'ON' at the bottom. A line points from the text 'Mode 4' to the '4' in the top left corner.

**Step 7**  
 To exit Setup, press and hold SELECT RUN MODE button for a few seconds until you return to Run screen.

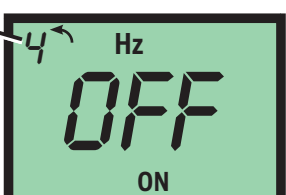

The LCD screen displays '4' in the top left corner, 'Hz' in the top right, the text 'OFF' in the center, and 'ON' at the bottom. A line points from the text 'Mode 4' to the '4' in the top left corner.

**11.1 Mode 4 - Pulse Batch Operation Screen Shots**

**Runtime Screen Shot 1**  
 Display **motor speed percentage**.  
 Pump Running in Pulse Batch Operation

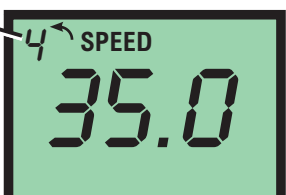

The LCD screen displays '4' in the top left corner, 'SPEED' in the top right, and the number '35.0' in the center. A line points from the text 'Mode 4' to the '4' in the top left corner.

**Runtime Screen Shot 2**  
 Display current number of pulses received  
 Press and release RIGHT arrow to view number of **pulses received** in real-time.

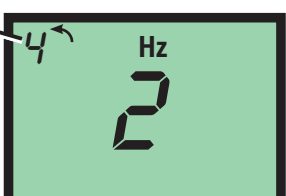

The LCD screen displays '4' in the top left corner, 'Hz' in the top right, the number '2' in the center, and a right-pointing triangle symbol to the left of the screen. A line points from the text 'Mode 4' to the '4' in the top left corner.

**Runtime Screen Shot 3**  
 Press and release RIGHT arrow again to view **mA output** value in real-time (available on select models only).  
 Press and release RIGHT arrow again to view **motor speed percentage**, as in Screen Shot 1.

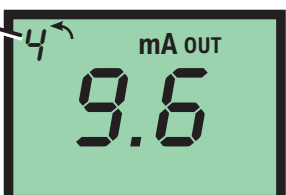

The LCD screen displays '4' in the top left corner, 'mA OUT' in the top right, the number '9.6' in the center, and a right-pointing triangle symbol to the left of the screen. A line points from the text 'Mode 4' to the '4' in the top left corner.

## 12.0 Pump Tube Timer

Flex-Pro has a built in Pump Tube Timer. Timer starts when rotor is rotating and stops when rotor is idle.

To view current Pump Tube Timer value, press and hold START button, then press and release DOWN arrow.

Tube Timer screen will appear. Screen will display current Pump Tube Time in run-time hours. Tube Timer screen will display for 4 seconds and then switch back to previous operating display screen.

While displayed, press START button twice to reset Pump Tube Timer to zero.

When replacing pump tube, pump will ask you if you'd like to reset Pump Tube Timer. If you choose YES, screen will display current Pump Tube Time for 5 seconds before timer is reset to zero.

### Tube Life Timer

Display tube life timer.  
Press and hold START button.  
Press and release DOWN arrow.

Displays amount of total runtime hours on currently installed tube.  
Time will be displayed in hours.  
Timer will be display for approximately 4 seconds before returning to previous runtime screen.

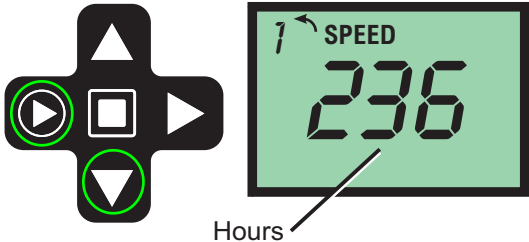

## 13.0 TFD (Tube Failure Detection)

Flex-Pro is equipped with a *Tube Failure Detection* System which is designed to stop pump and provide an output alarm in event pump tube should rupture and chemical enters pump head. Pump will detect a chemical with a conductivity reading greater than 500 microsiemens. Chemicals with a conductivity of less than 500 microsiemens will not be detected.

This patented system is capable of detecting presence of a large number of chemicals including Sodium Hypochlorite (Chlorine), Hydrochloric (muriatic) Acid, Sodium Hydroxide, and many others. System will not be triggered by water (rain, condensation, etc.) or silicone oil (roller and tubing lubricant).

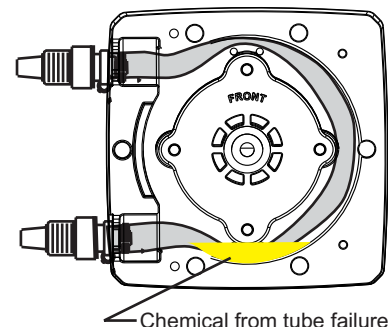

If system has detected chemical, pump tube must be replaced and pump head and roller assembly must be thoroughly cleaned. Failure to clean roller assembly will void warranty.

If TFD alarm occurs, pump will stop, close an alarm output, and screen will flash TFD with an alarm icon.

### Confirm Chemical Detection

To determine if your chemical will be detected by system, remove pump head cover and pump tube and roller assembly.

Place a small amount of chemical in bottom of pump head - just enough to cover sensors. Replace pump head cover only.

Turn on pump (press START). If TFD system detects chemical, pump will stop after a two second confirmation period and TFD Alarm screen will display. If TFD system does not detect chemical, pump will continue to run after confirmation period.

Carefully clean chemical out of pump head being sure to remove all traces of chemical from sensor probes. Replace roller assembly and tubing. Replace pump head cover. Press START button to clear alarm condition and restart pump.

## 14.0 Alarm Relay

Pump has a built in 3 amp alarm output relay. Relay is pre-configured to energize on tube failure detection (TFD) and on Flow Verification Sensor (FVS).

A Flow Verification Sensor must be installed and configured for relay to trigger on no-flow conditions.

## 15.0 Reverse Rotor Rotation

<b>CAUTION</b> ⚠	Prior to service, pump clean water through pump and suction / discharge line to remove chemical.
---------------------	--

<b>CAUTION</b> ⚠	Always wear protective clothing, face shield, safety glasses and gloves when working on or near your metering pump. Additional precautions should be taken depending on solution being pumped. Refer to MSDS precautions from your solution supplier.
---------------------	---

Reverse rotation of pump; press and hold REVERSE ROTATION button until rotor begins rotating in opposite direction. This process can be used for many reasons throughout various industries.

Two reasons for reversing current rotor rotation; to purge chemical from tubing and to extend tube life.

Plan ahead before reversing rotor rotation. If check valves are installed, make necessary arrangements to allow back flow.

<b>CAUTION</b> ⚠	Failure to install check valves in their proper flow direction can cause excess pressure (PSIg) build up in system and can result in tube rupture. Always use extreme caution and ensure proper connections when using this feature.
---------------------	--

If your desire is to simply extend tube life:

Typically tubing fails on outlet side (pressure side) of tube assembly in pump head.

Reversing rotation, moves outlet side (pressure side) to opposite side of tube assembly, greatly increasing tube life.

Stop pump before tube failure occurs.





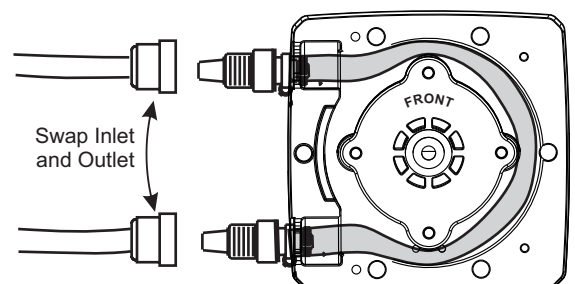
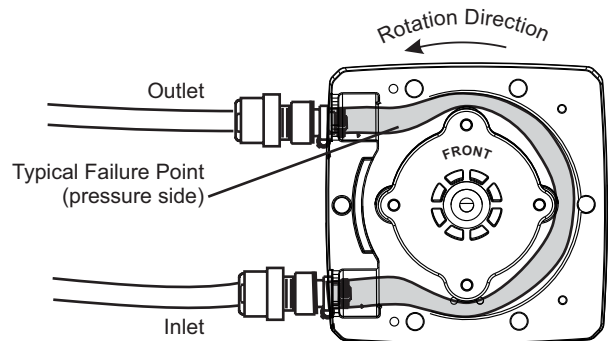

Disconnect power from pump. Carefully purge any pressure in discharge line of pump. Disconnect suction end tubing and discharge end tubing from pump head tubing.

**IMPORTANT!** Swap sides of suction (inlet) and discharge (outlet) tubing. No need to remove Pump Head Cover.

Double check all connections before starting pump.



## 16.0 Tube Replacement

<b>CAUTION</b> 	Prior to service, pump clean water through pump and suction / discharge line to remove chemical.
<b>CAUTION</b> 	Always wear protective clothing, face shield, safety glasses and gloves when working on or near your metering pump. Additional precautions should be taken depending on solution being pumped. Refer to MSDS precautions from your solution supplier.
<b>CAUTION</b> 	Use provided Tube Installation Tool to leverage tubing into pump head, <b><u>NOT YOUR FINGERS.</u></b>
<b>CAUTION</b> 	Use extreme caution when replacing pump tube. <b><u>DO NOT</u></b> place fingers near rollers.

## 16.1 Tube Removal

### Step 1

**Wear protective clothing, face shield, safety glasses and gloves during tube replacement.**

Relieve (remove) system pressure on discharge and suction side of pump. Failure to do so will cause solution to squirt when disconnecting tube connections. **SAFETY FIRST, REMOVE PRESSURE...**

Disconnect system plumbing from pump tube adapters.



### Step 2

Press and release STOP button.

Remove four black thumb screws from front of pump head cover. Turn screws counterclockwise to remove.

Remove pump head cover by pulling straight out.

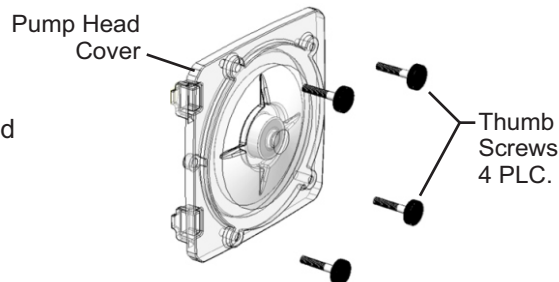

### Step 3

With pump stopped, securely grab hold of suction side of tube adapter.

**CAUTION!** Keep fingers away from rollers and rotor.

Press and release START button to allow rotation of rotor.

Gently pull suction side tube adapter out, away from pump.

Suction side tube adapter

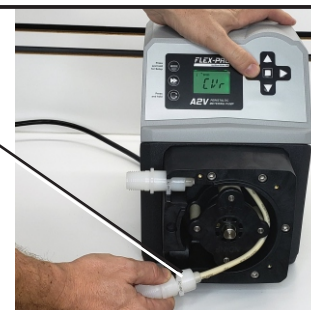

### Step 4

Continue to pull suction side adapter out of pump head while rotor is in rotation.

Press and release STOP button.

Carefully pull discharge side of tube adapter out of pump head.

Dispose of used tubing properly.

Discharge side tube adapter





## 16.2 Tube Installation

**Before you begin.** Thoroughly clean Pump Head and Rotor. Rotor can be removed by pulling straight out. After cleaning process, push Rotor back on shaft. See drawing below for proper assembly. **IMPORTANT!** Rotor direction; word "FRONT" on Rotor must face forward (front of pump).

**Step 1**

Press and release stop button to ensure pump is stopped.

With pump stopped, press suction side of tube adapter securely into pump head.

Clip Tube Installation Tool to discharge side of tube adapter.

Always keep fingers away from rollers and rotor.

Installation Tool

Suction side tube adapter



**Step 2**

Your hand should only come in contact with installation tool.

Press and release START button.

Use installation tool to leverage tubing into pump head while rotor is rotating.

Installation Tool



**Step 3**

Continue to hold onto installation tool.

Allow rotor to rotate a few times, this will stretch tubing out.

After a few rotations, pull installation tool and tubing in direction of rotation.

Press discharge side of tube adapter securely into pump head.

PULL

Discharge side tube adapter

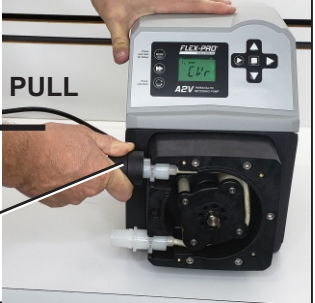

**Step 4**

Press and release STOP button on pump.

Suction and discharge tube adapter ends should be securely held in place on pump head as illustrated in photo.

Secure pump head cover to pump head using four black thumb screws.

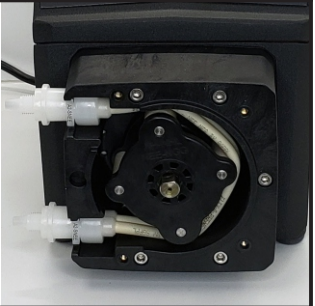

TIP! Apply silicone oil to outside of Flex-A-Thane tube for longer life.



**Tube Installation Tool**  
90002-278

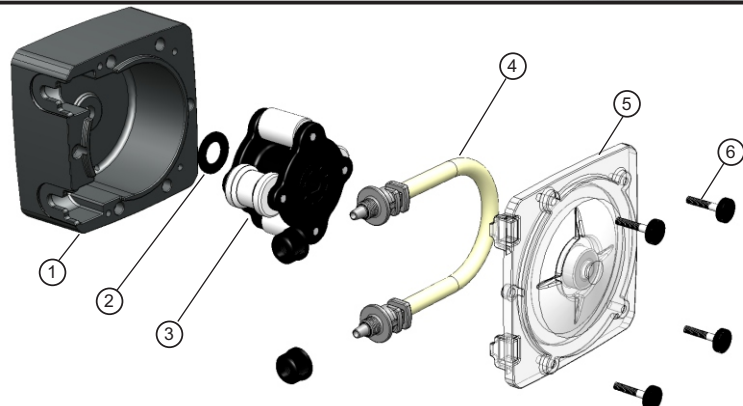

## 17.0 Pump Maintenance

**CAUTION**

Always wear protective clothing, face shield, safety glasses and gloves when working on or near your metering pump. Additional precautions should be taken depending on solution being pumped. Refer to MSDS precautions from your solution supplier.

### Routine Inspection and Maintenance

Pump requires very little maintenance. However, pump and all accessories should be checked weekly. This is especially important when pumping chemicals. Inspect all components for signs of leaking, swelling, cracking, discoloration or corrosion. Replace worn or damaged components immediately.

Cracking, crazing, discoloration during first week of operation are signs of severe chemical attack. If this occurs, immediately remove chemical from pump. Determine which parts are being attacked and replace them with parts that have been manufactured using more suitable materials. Manufacturer does not assume responsibility for damage to pump that has been caused by chemical attack.

### How to Clean and Lubricate Pump

Pump will require occasional cleaning. Amount will depend on severity of service.

- ☒ When changing pump tube assembly, pump head chamber, roller assembly and pump head cover should be wiped free of any dirt and debris.
- ☒ When changing pump tube assembly, wipe motor shaft with clean towel. Apply a small amount of grease to shaft. This will help prevent possibility of rotor sticking to motor shaft.
- ☒ Pump head cover bearing may require grease periodically. Apply a small amount of grease (Aeroshell aviation grease #5 or equivalent) when necessary.
- ☒ Although not necessary, 100% silicone lubrication may be used on roller assembly.
- ☒ Periodically clean injection/check valve assembly, especially when injecting fluids that calcify such as sodium hypochlorite. These lime deposits and other build ups can clog fitting, increase back pressure and interfere with check valve operation.
- ☒ Periodically clean suction strainer.

18.0 Output Versus Fluid Viscosity

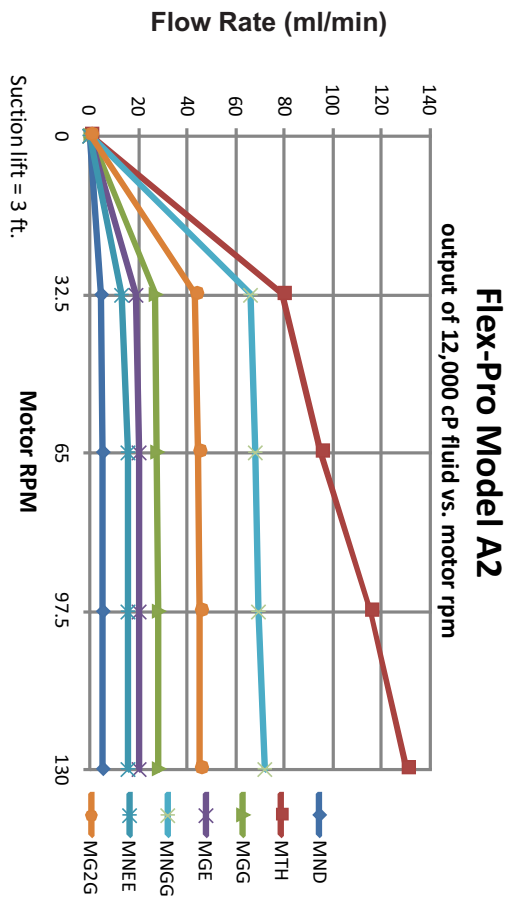
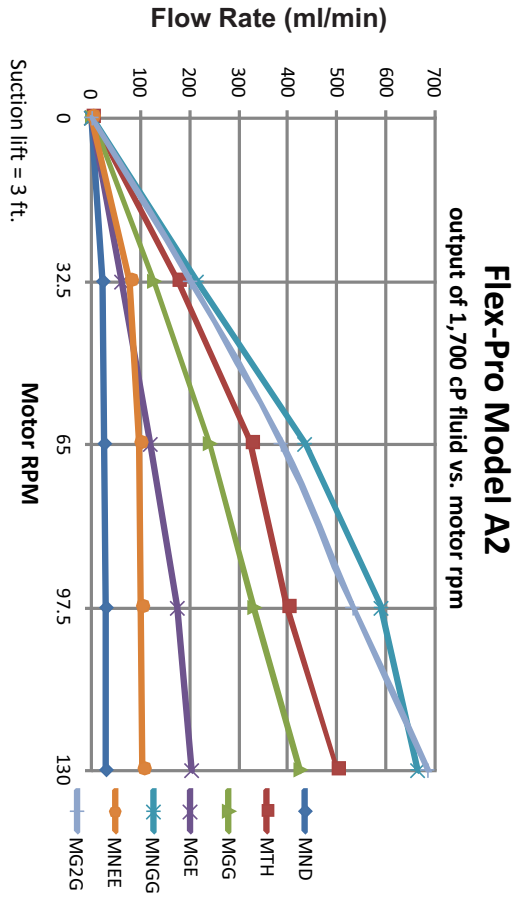
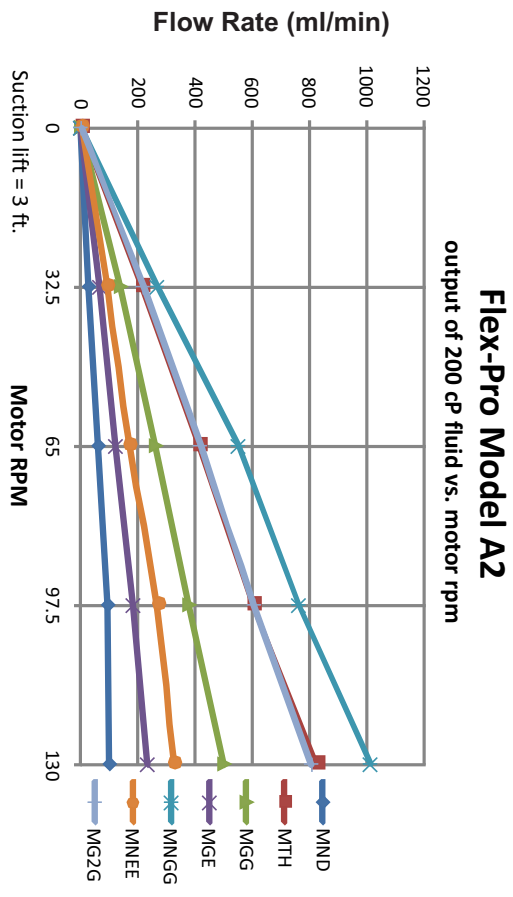
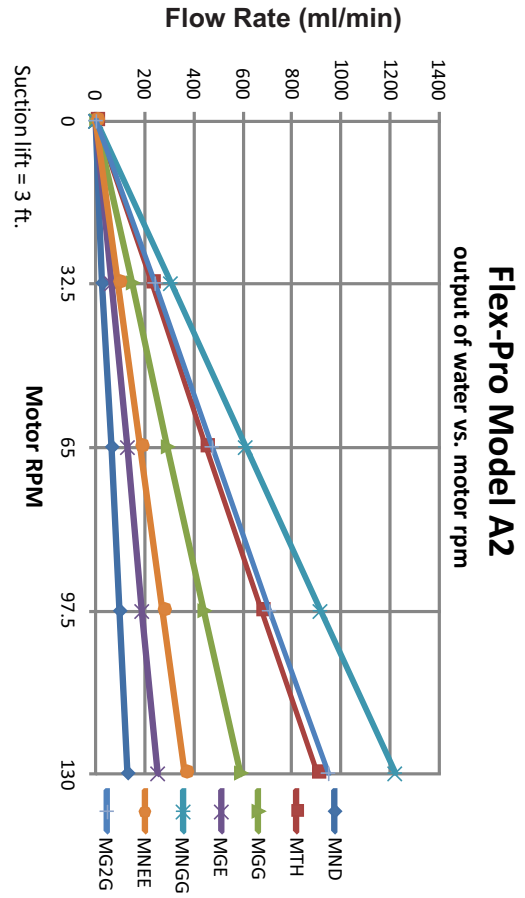

## 19.0 A2 Replacement Parts List

### Pump Head Components

<b>1</b>	Spacer	90011-217	1	\$1.42
<b>2</b>	Complete Roller Assembly		1	\$570.67
	ND	A2-SND-R		
	NEE / NGG	A2-SNGG-R		
	TH	A2-STH-R		
	GE / GG	A2-SGE-R		
<b>3</b>	Tubing ( <b>Reference Tubing Matrix</b> )		1	
<b>4</b>	Pump Head Cover	A2-SXX-C	1	\$200.78
<b>5</b>	Thumb Screws	90011-183	4	\$8.32
<b>6</b>	Tube Nut, COMPRESSION 3/8" Tubing	C-330-6	2	\$3.11

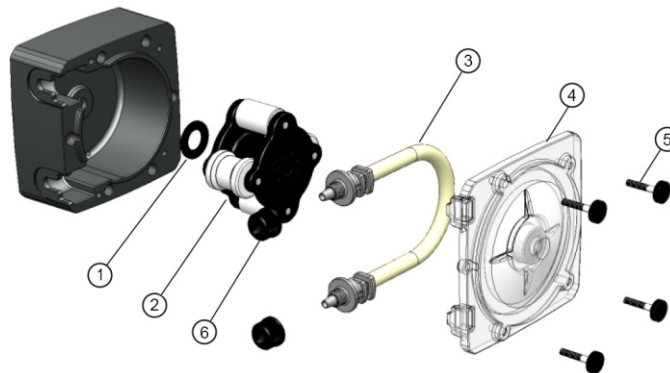

\*Pump Head not for sale. For more information please contact a local sales representative.

### Quick Disconnect Fittings (only available for Q tubes)

<b>7</b>	Quick Disconnect		1	\$350.17
	.50" Barb FKM	KIT-QBV		
	.50" Barb EP	KIT-QBE		
	.50" M/NPT FKM	KIT-QMV		
	.50" M/NPT EP	KIT-QME		
	3/8" OD, 1/4" ID Tube Compression, FKM	KIT-QSV		
	3/8" OD, 1/4" ID Tube Compression, EP	KIT-QSE		



7

### Miscellaneous Parts (Sold Separately)

<b>A</b>	Stainless Steel Mounting Bracket (Extended)	72000-380	1	\$59.72
<b>B</b>	Rubber Feet	90003-561	1	\$5.98
<b>C</b>	Tube Installation Tool	90002-278	1	\$6.35



A



B



C

## 19.1 Tube Matrix

**A2** Tubing

### Inlet/Outlet Connection Size, Connection Type, Connection Material

<b>S</b>	3/8" OD x 1/4" ID Tube Compression Fitting, Natural PVDF (Kynar)
<b>M</b>	1/2" Male NPT Fitting, Natural PVDF (Kynar)
<b>B</b>	1/2" Hose Barb, Natural PVDF (Kynar), available for ND, NEE, NGG, and G2G only
<b>C</b>	1/2" - 3/4" Tri-clamp connections, Natural PVDF (Kynar), available for ND, NEE, NGG, and G2G only
<b>Q</b>	Quick Disconnect, Natural PVDF (Kynar), available for NDD, NEE, NGG, and G2G only (valves sold seperately)
<b>MB</b>	MB 1/2" Male BSPT Fitting, Natural PVDF (Kynar)

### Pump Tube Material, Pump Tube Size

<b>GE</b>	Flex-A-Thane® .125 ID
<b>GG</b>	Flex-A-Thane® .187 ID
<b>G2G</b>	Flex-A-Thane® .187 ID
<b>ND</b>	Flex-A-Prene® .075 ID
<b>NEE</b>	Flex-A-Prene® .093 ID
<b>NGG</b>	Flex-A-Prene® .187 ID
<b>TH</b>	Flex-A-Chem® .250 ID

**A2** - **S** **GE** - **T** Tube Sample Model Number

## Output Specifications

Tube Material / Size	Feed Rate			Max Pressure	Max Temperature
	GPH	LPH	mL/Min	PSI (bar)	°F (°C)
<b>Flex-A-Thane® Tube</b>					
GE	Up to 4.0	Up to 15.2	Up to 253	65 (4.50)	130 (54)
GG	Up to 9.3	Up to 35.2	Up to 587	65 (4.50)	130 (54)
G2G	Up to 14.98	Up to 56.7	Up to 945	65 (4.50)	130 (54)
<b>Flex-A-Prene® Tube</b>					
ND	Up to 1.7	Up to 6.5	Up to 108	125 (8.60)	185 (85)
NEE	Up to 4.44	Up to 16.8	Up to 280	110 (7.60)	185 (85)
NGG	Up to 17.2	Up to 65.1	Up to 1085	110 (7.60)	185 (85)
<b>Flex-A-Chem® Tube</b>					
TH	Up to 14.3	Up to 54	Up to 900	50 (3.45)	130 (54)

## 20.0 WARRANTY

### 20.1 LIMITED WARRANTY

Your new FLEXFLO pump is a quality product and is warranted for 24 months from date of purchase (proof of purchase is required). The pump will be repaired or replaced at our discretion. Failure must have occurred due to defect in material or workmanship and not as a result of operation of the product other than in normal operation as defined in the pump manual. Warranty status is determined by the pump's serial label and the sales invoice or receipt. The serial label must be on the pump and legible. The warranty status of the pump will be verified by Blue-White or a factory authorized service center.

Pump Head and roller assembly is warranted against damage from chemical attack when proper TFD (Tube Failure Detection) system instructions and maintenance procedures are followed.

### 20.2 WHAT IS NOT COVERED

- Pump Tube Assemblies and rubber components – They are perishable and require periodic replacement.
- Pump removal, or re-installation, and any related labor charge.
- Freight to the factory, or service center.
- Pumps that have been tampered with, or in pieces.
- Damage to the pump that results from misuse, carelessness such as chemical spills on the enclosure, abuse, lack of maintenance, or alteration which is out of our control.
- Pumps damaged by faulty wiring, power surges or acts of nature.

### 20.3 PROCEDURE FOR IN WARRANTY REPAIR

Contact the factory to obtain a RMA (Return Material Authorization) number. Carefully pack the pump to be repaired. It is recommended to include foot strainer and injection/check valve fitting since these devices may be clogged and part of the problem. Please enclose a brief description of the problem as well as the original invoice or sales receipt, or copy showing the date of purchase. Prepay all shipping costs. COD shipments will not be accepted. Warranty service must be performed by the factory or an authorized service center. Damage caused by improper packaging is the responsibility of the sender. When In-Warranty repair or replacement is completed, the factory pays for return shipping to the dealer or customer.

### 20.4 PRODUCT USE WARNING

Blue-White products are manufactured to meet the highest quality standards in the industry. Each product instruction manual includes a description of the associated product warranty and provides the user with important safety information. Purchasers, installers, and operators of Blue-White products should take the time to inform themselves about the safe operation of these products. In addition, Customers are expected to do their own due diligence regarding which products and materials are best suited for their intended applications. Blue-White is pleased to assist in this effort but does not guarantee the suitability of any particular product for any specific application as Blue-White does not have the same degree of familiarity with the application that the customer/end user has. While Blue-White will honor all of its product warranties according to their terms and conditions, Blue-White shall only be obligated to repair or replace its defective parts or products in accordance with the associated product warranties. **BLUE-WHITE SHALL NOT BE LIABLE EITHER IN TORT OR IN CONTRACT FOR ANY LOSS OR DAMAGE WHETHER DIRECT, INDIRECT, INCIDENTAL, OR CONSEQUENTIAL, ARISING OUT OF OR RELATED TO THE FAILURE OF ANY OF ITS PARTS OR PRODUCTS OR OF THEIR NONSUITABILITY FOR A GIVEN PURPOSE OR APPLICATION.**

### 20.5 CHEMICAL RESISTANCE WARNING

Blue-White offers a wide variety of wetted parts. Purchasers, installers, and operators of Blue-White products must be well informed and aware of the precautions to be taken when injecting or measuring various chemicals, especially those considered to be irritants, contaminants or hazardous. Customers are expected to do their own due diligence regarding which products and materials are best suited for their applications, particularly as it may relate to the potential effects of certain chemicals on Blue-White products and the potential for adverse chemical interactions. Blue-White tests its products with water only. The chemical resistance information included in this instruction manual was supplied to Blue-White by reputable sources, but Blue-White is not able to vouch for the accuracy or completeness thereof. While Blue-White will honor all of its product warranties according to their terms and conditions, Blue-White shall only be obligated to repair or replace its defective parts or products in accordance with the associated product warranties. **BLUE-WHITE SHALL NOT BE LIABLE EITHER IN TORT OR IN CONTRACT FOR ANY LOSS OR DAMAGE, WHETHER DIRECT, INDIRECT, INCIDENTAL, OR CONSEQUENTIAL, ARISING OUT OF OR RELATED TO THE USE OF CHEMICALS IN CONNECTION WITH ANY BLUE-WHITE PRODUCTS.**

## 21.0 Model Number Matrix

**A2** FLEXFLO® Peristaltic Metering Pump

### Series Control Options

<b>F</b>	Single manual output control (manual/local control only)
<b>V</b>	Multiple automatic input output control and alarm modes (remote control)

### Power Cord (operating voltage requirement 96VAC to 264VAC)

<b>4</b>	115V / 60Hz, power cord NEMA 5/15 plug (US)	<b>8</b>	240V / 50HZ, power cord AS 3112 plug (AU/New Zealand)
<b>5</b>	230V / 60Hz, power cord NEMA 6/15 plug (US)	<b>9</b>	230V / 50HZ, power cord BS 1363 plug (UK)
<b>6</b>	220V / 50HZ, power cord CEE 7/VII plug (EU)	<b>X</b>	No Power Cord

### Inlet/Outlet Connection Size, Connection Type, Connection Material

<b>S</b>	3/8" OD x 1/4" ID Tube Compression Fitting, Natural PVDF (Kynar)
<b>M</b>	1/2" Male NPT Fitting, Natural PVDF (Kynar)
<b>B</b>	1/2" ID Tubing Barb Fitting, Natural PVDF (Kynar), available for ND, NEE, NGG, G2G only
<b>C</b>	1/2" - 3/4" Tri-clamp connections, Natural PVDF (Kynar), available for ND, NEE, NGG, and G2G only
<b>Q</b>	Quick Disconnect, Natural PVDF (Kynar), available for ND, NEE, NGG, and G2G only (valves sold seperately)
<b>MB</b>	1/2" Male BSPT Fitting, Natural PVDF (Kynar)

### Pump Tube Material, Pump Tube Size

<b>ND</b>	Flex-A-Prene® .078 ID, 0.01 to 1.7 GPH	<b>GE</b>	Flex-A-Thane® .125 ID, 0.02 to 4.0 GPH
<b>NEE</b>	Flex-A-Prene® .093 ID, 0.022 to 4.44 GPH	<b>GG</b>	Flex-A-Thane® .187 ID, 0.05 to 9.3 GPH
<b>NGG</b>	Flex-A-Prene® .187 ID, 0.086 to 17.2 GPH	<b>TH</b>	Flex-A-Chem® .250 ID, 0.08 to 14.9 GPH
<b>G2G</b>	Flex-A-Thane® .187 ID, 0.07 - 14.98 GPH		

### Options (leave this blank for standard model with left facing pump head inlet/outlet)

<b>1</b>	TI40-6V Threadless injection check valve, replaces A-014NK-6A threaded check valve
<b>2</b>	C340A Foot valve, replaces standard C-342 inlet strainer (no check valve)
<b>3</b>	4-20 mA analog output (requires "V" series control)
<b>R</b>	Right facing pump head, input / output (Left facing fluid input / output is standard)
<b>D</b>	Down facing pump head, input / output (Left facing fluid input / output is standard)

<b>A2</b>	<b>F</b>	<b>2</b>	<b>4</b>	<b>-</b>	<b>S</b>	<b>ND</b>	<b>-</b>	<b>1</b>	<b>Sample Model Number</b>
-----------	----------	----------	----------	----------	----------	-----------	----------	----------	----------------------------

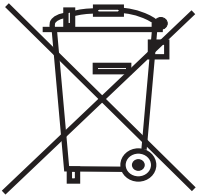

Users of electrical and electronic equipment (EEE) with the WEEE marking per Annex IV of the WEEE Directive must not dispose of end of life EEE as unsorted municipal waste, but use the collection framework available to them for the return, recycle, recovery of WEEE and minimize any potential effects of EEE on the environment and human health due to the presence of hazardous substances. The WEEE marking applies only to countries within the European Union (EU) and Norway. Appliances are labeled in accordance with European Directive 2002/96/EC.

Contact your local waste recovery agency for a *Designated Collection Facility* in your area.

**Blue-White**<sup>®</sup>

5300 Business Drive  
Huntington Beach, CA 92649  
USA

TEL: 714-893-8529  
FAX: 714-894-9492

[www.blue-white.com](http://www.blue-white.com)  
[sales@blue-white.com](mailto:sales@blue-white.com)  
[customerservice@blue-white.com](mailto:customerservice@blue-white.com)