

pH and chlorine cell housing for water analysis

Transparent measuring chambers are used for a better view of water circulation. Adaptable in monobloc or modular version, these chambers can receive from 1 to several probes and sensors measures: chlorine, bromine, pH, temperature, ORP, TDS, ozone ...

Advantages of transparent measuring cells

- ✓ Monobloc cells designed for industrial applications, drinking water, hot water systems (max. 70°C), process water...
- ✓ The block material is PMMA (Acrylic) and the seals are made of EPDM, FPM,
- ✓ Clear flow cells that can be adapted to all types of amperometric or other sensors: chlorine, ph, temperature, ozone...
- ✓ Flow rate adjustment by micrometric screw,
- ✓ The magnetic float offers a complete visualization of the fluid flow in the measurement cell
- ✓ The fitting material can be PVC or PVDF depending on the application,
- ✓ Max. Temperature 40°C for PVC and 70°C for PVDF.

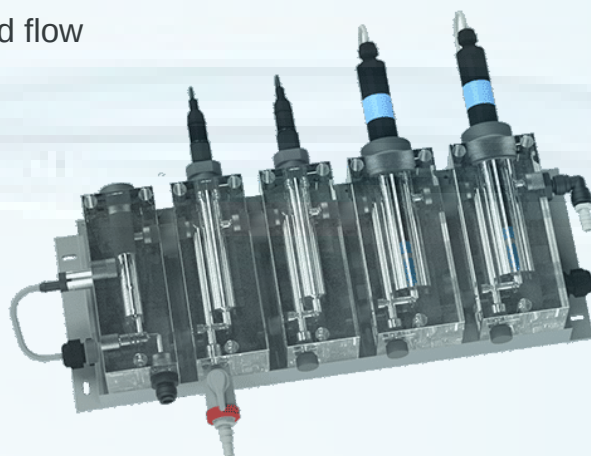

Measurement options

- Free or total chlorine by membrane amperometric probe and stabilizer compatible
- Active chlorine by membrane amperometric probe,
- pH,
- TDS,
- Temperature,
- Redox (ORP)



Applications

- Process industries
- Drinking water
- Sanitary hot water
- Recreational waters